

AR

Broadbent Auction Reserve

BROADBENT SELECTIONS

Bb000

Broadbent 2000 EDN

BROADBENT SELECTIONS

Ni11

JDAW Niepoort 2011

BROADBENT SELECTIONS

F85

JDAW Fonseca 1985

BROADBENT SELECTIONS

Bb94

Broadbent 1994 BB

BROADBENT SELECTIONS

Bb03

Broadbent 2003 EDN

BROADBENT SELECTIONS

Bb11

Broadbent 2011 EDN

BROADBENT SELECTIONS

Ps92

Niepoort Quinta do Passadouro 1992 CPR

BROADBENT SELECTIONS

GC83

Could Campbell 1983 MPM

BROADBENT SELECTIONS

Bb97

Broadbent 1997 BB

BROADBENT SELECTIONS

Bb07

Broadbent 2007 EDN

BROADBENT SELECTIONS

Bb15

Broadbent 2015 EDN

BROADBENT SELECTIONS

W91

Warre 1991 PW

BROADBENT SELECTIONS

???

"Novelty" AHB

BROADBENT SELECTIONS



Bartholomew B.

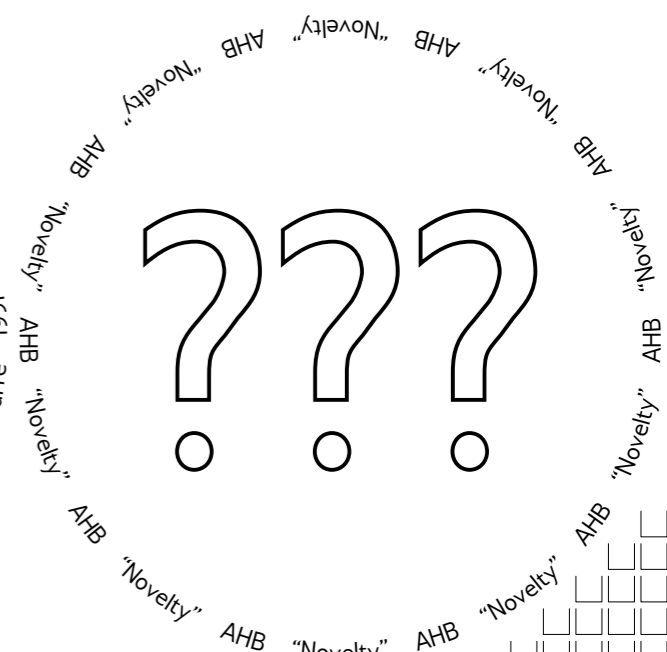
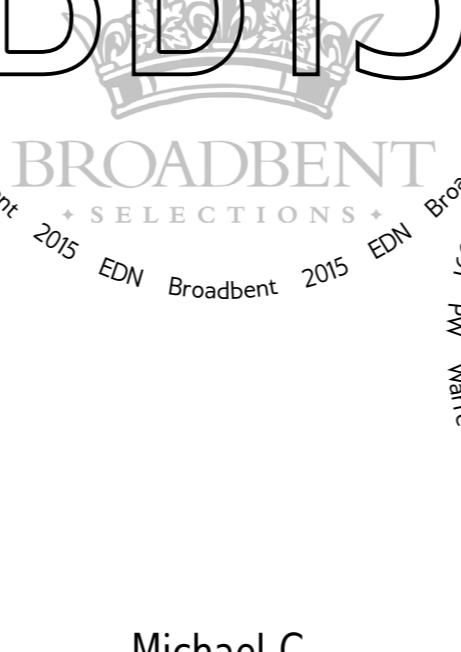
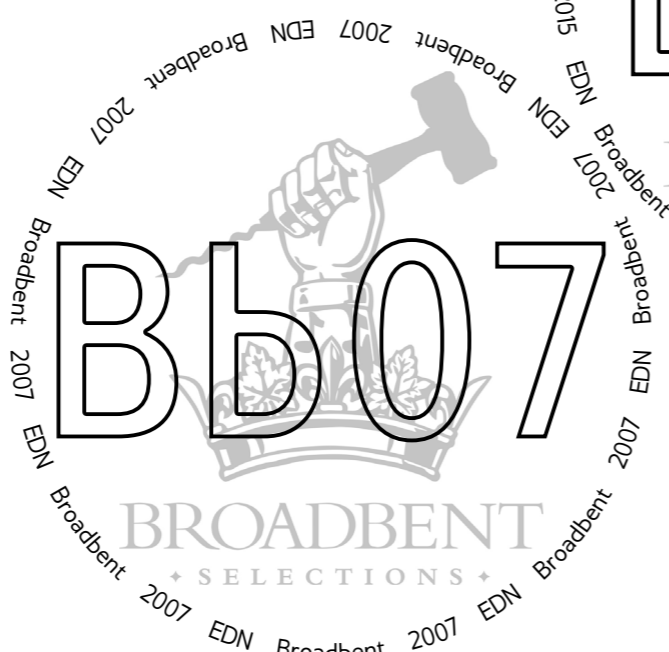
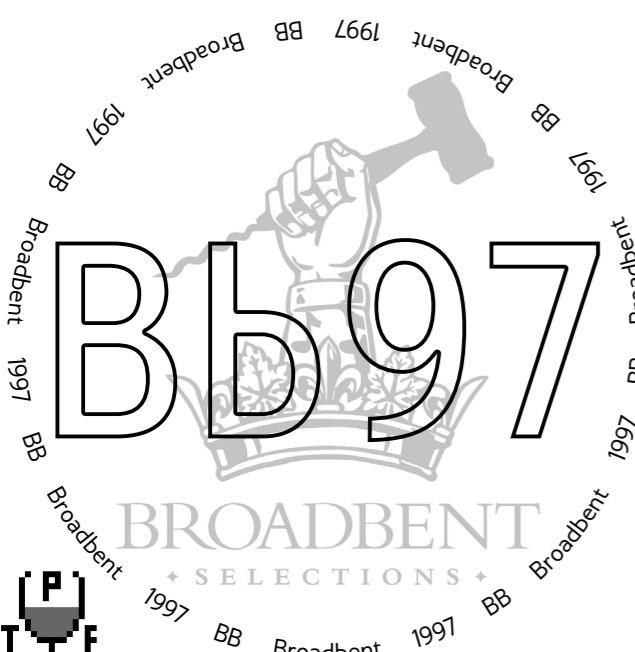
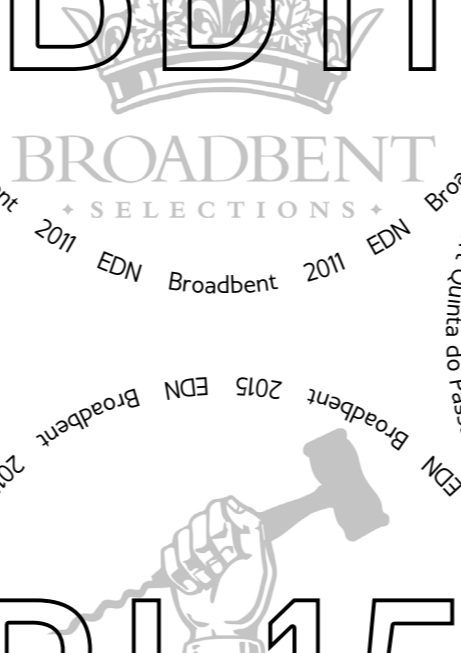
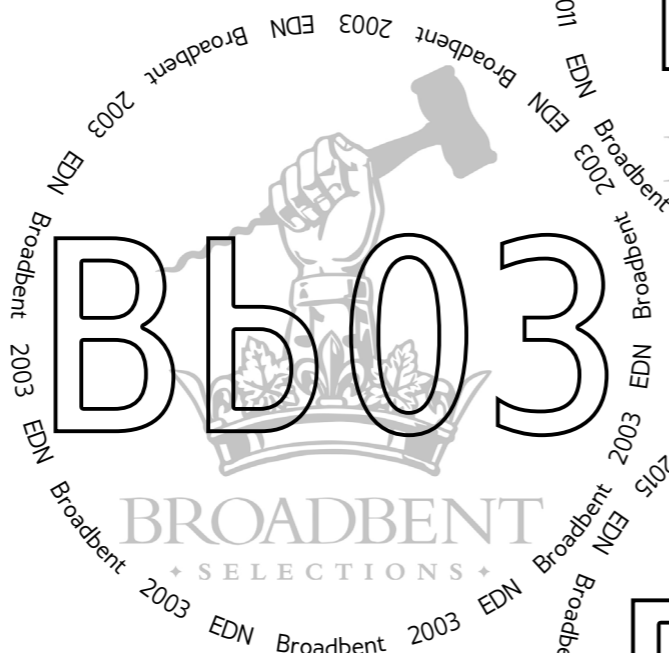
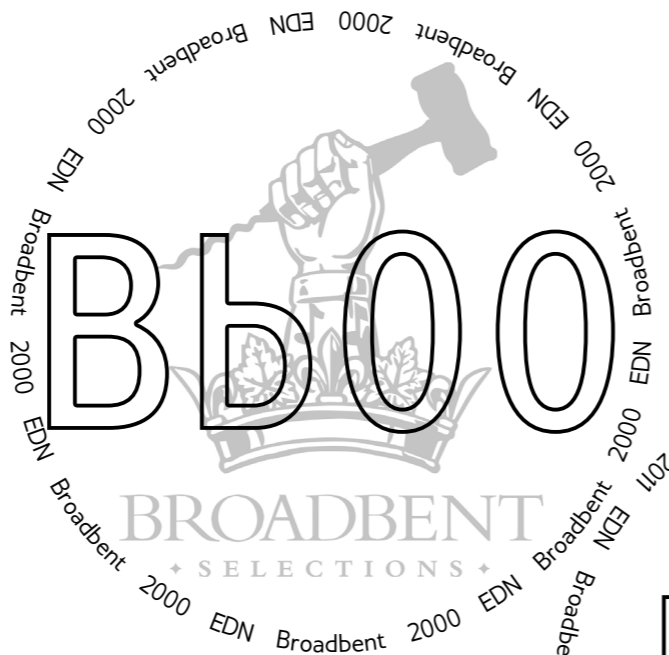

Michael C.



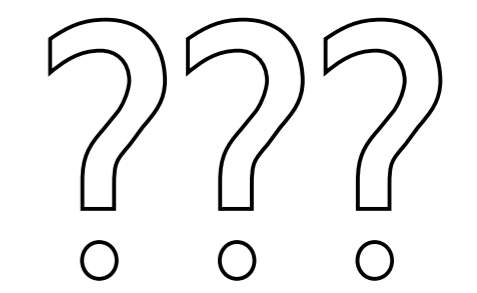
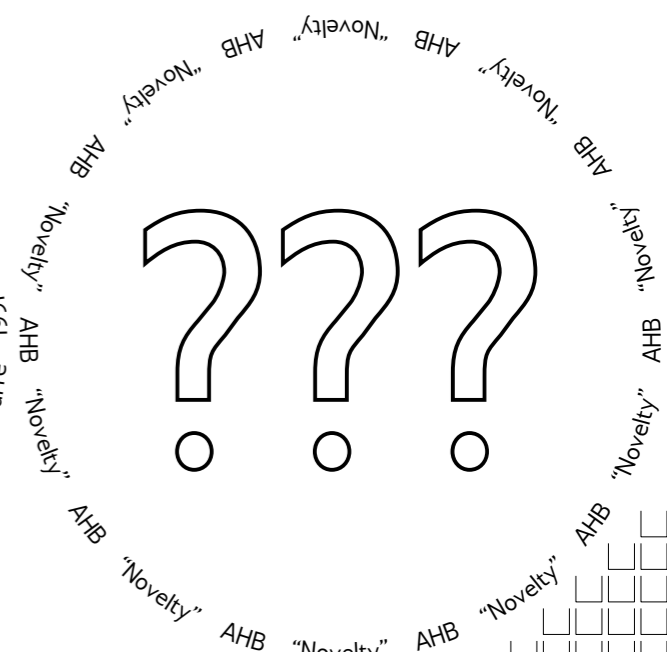
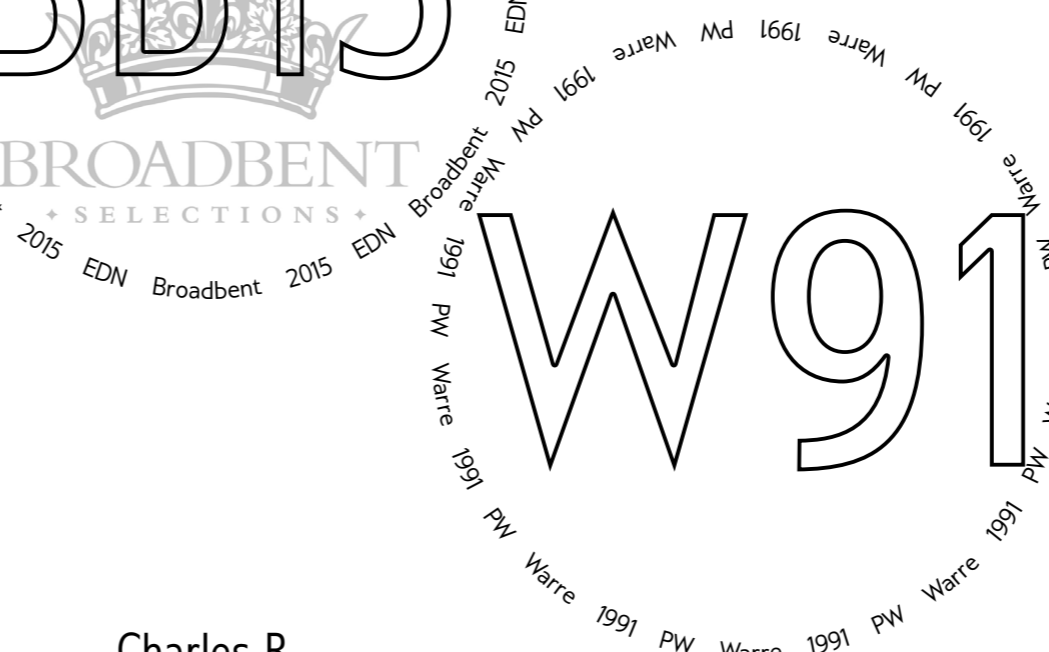
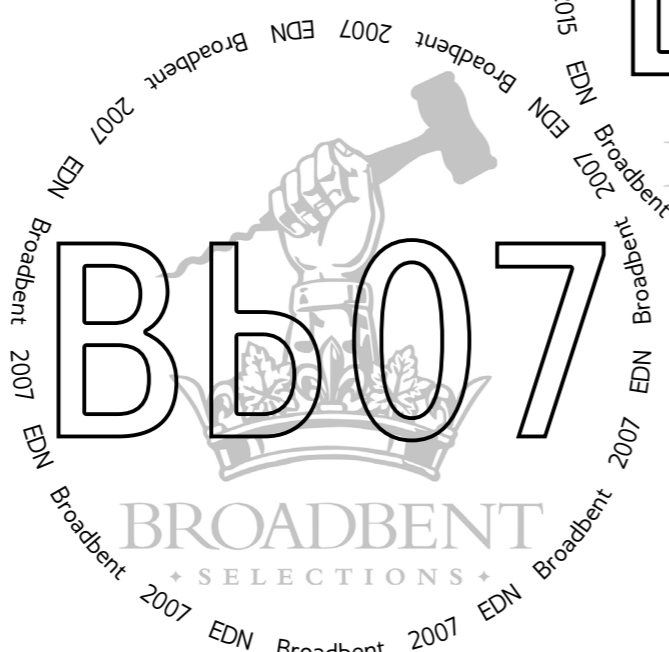
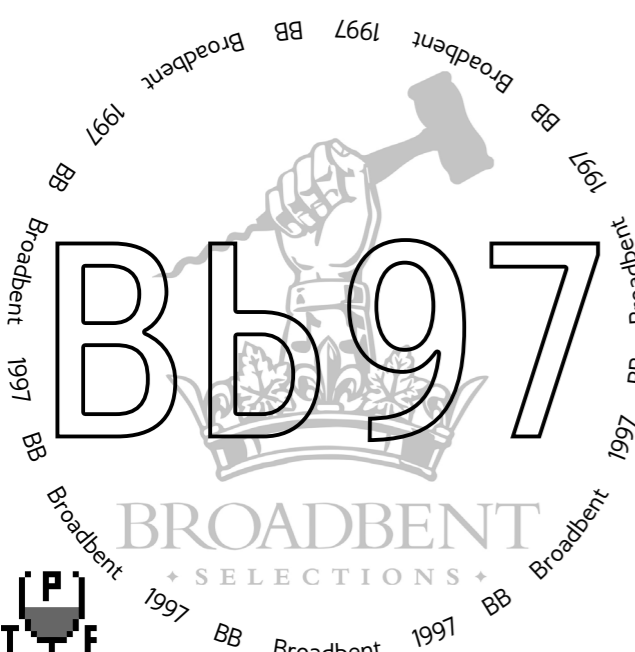
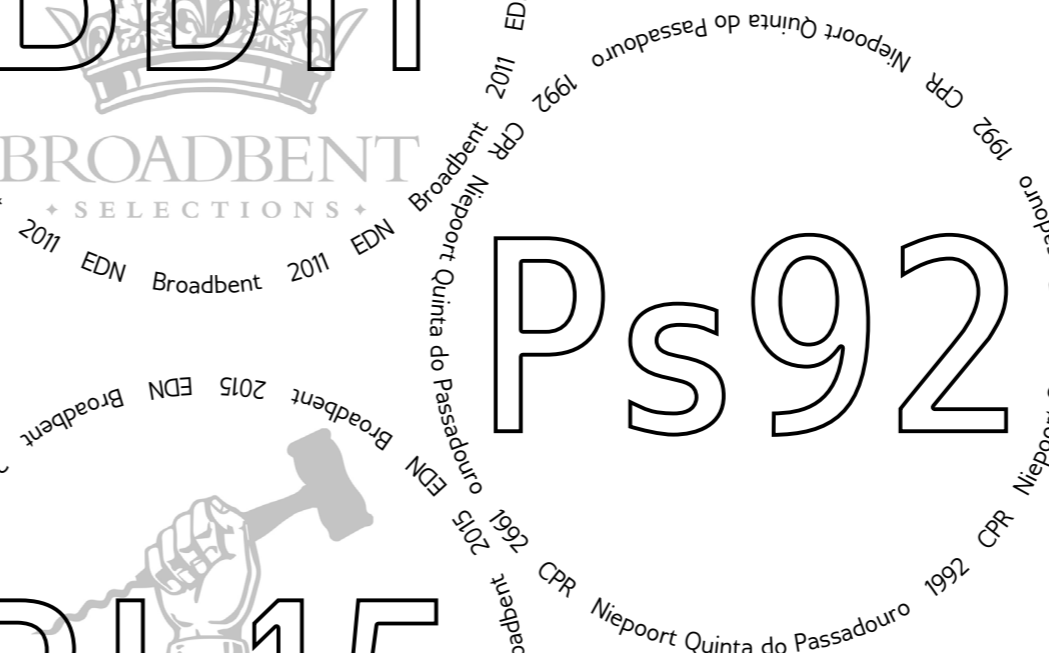
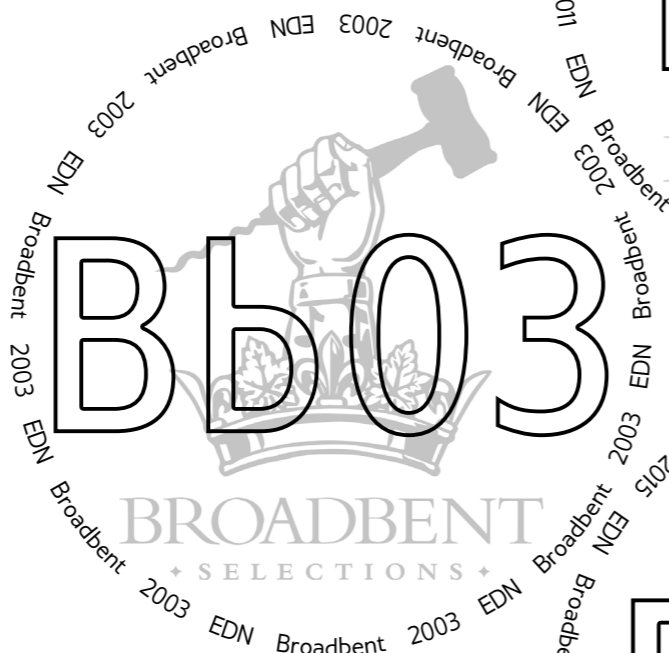
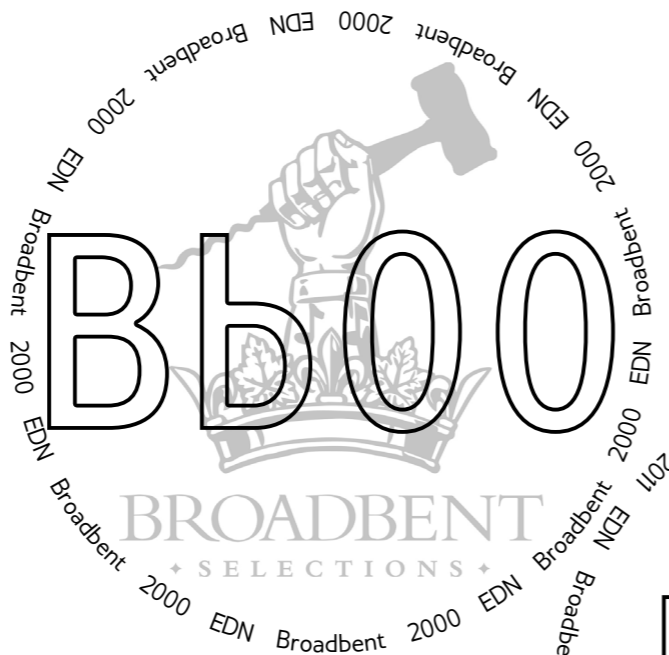

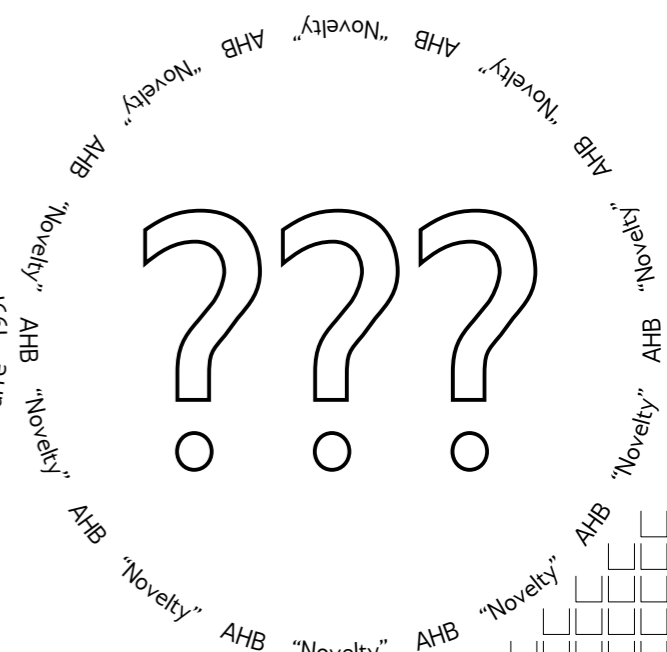
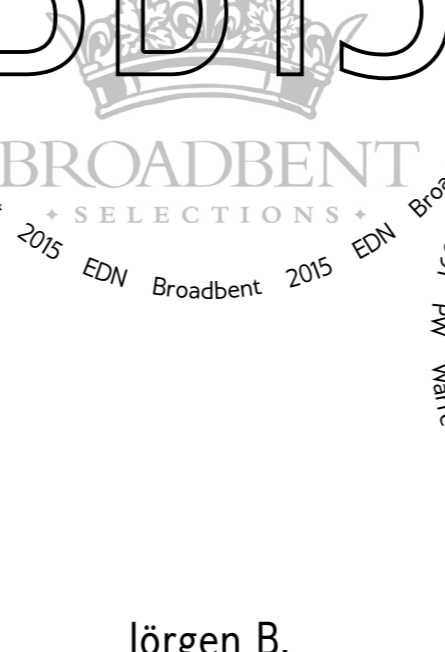
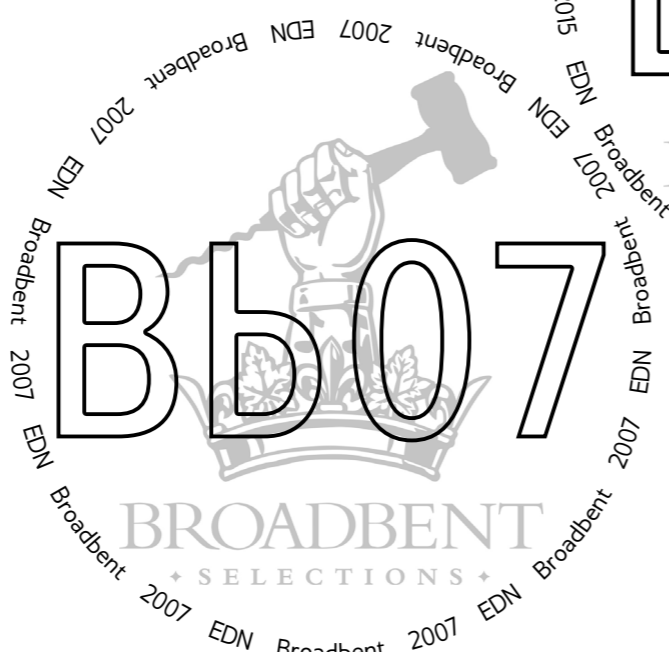
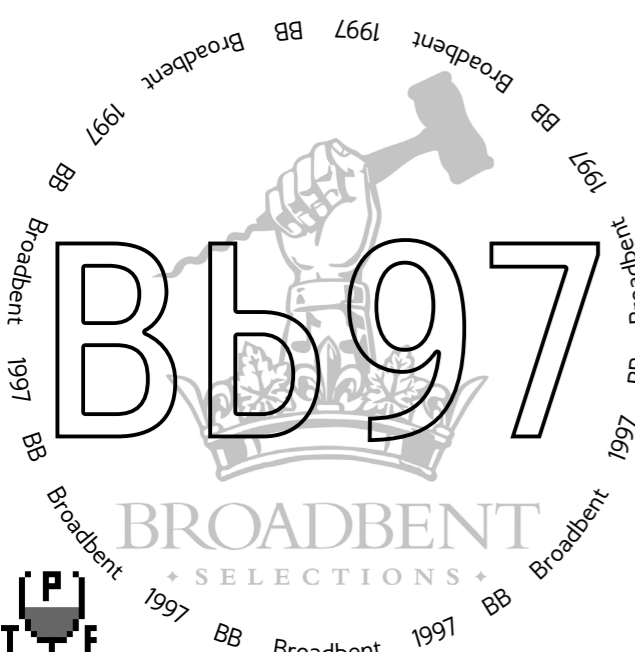
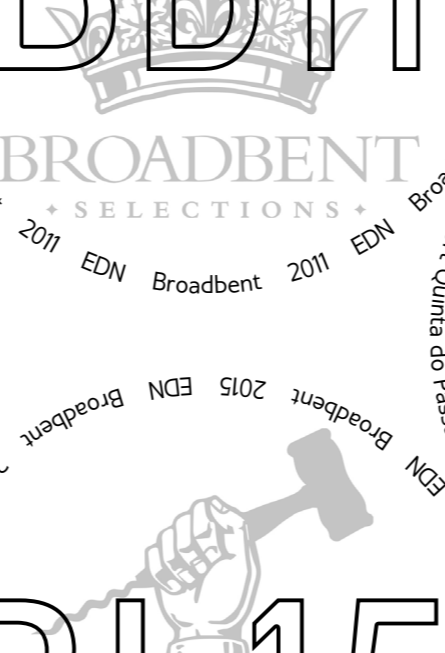
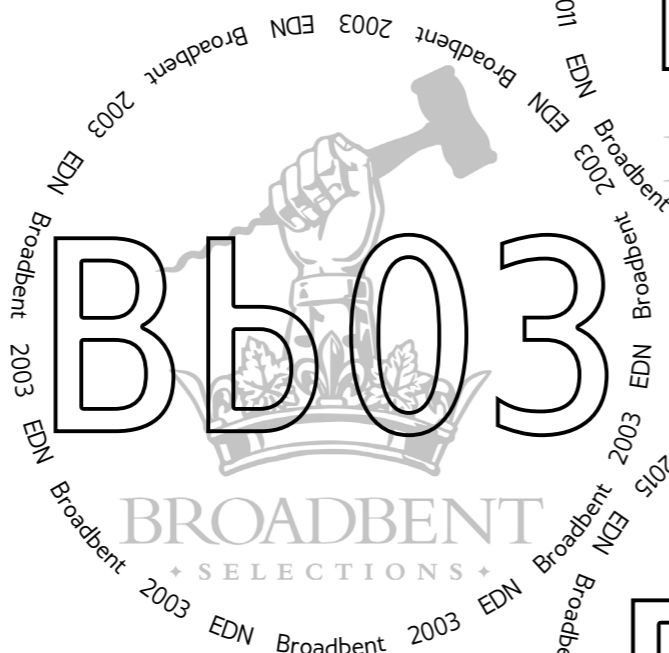
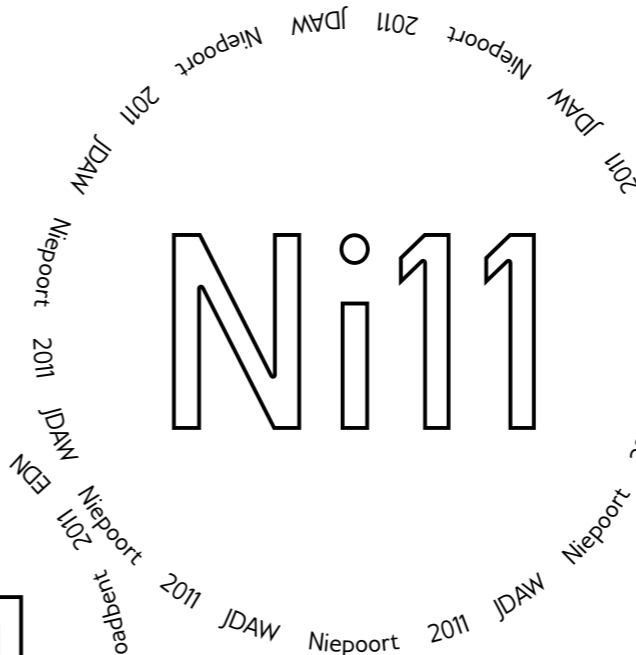
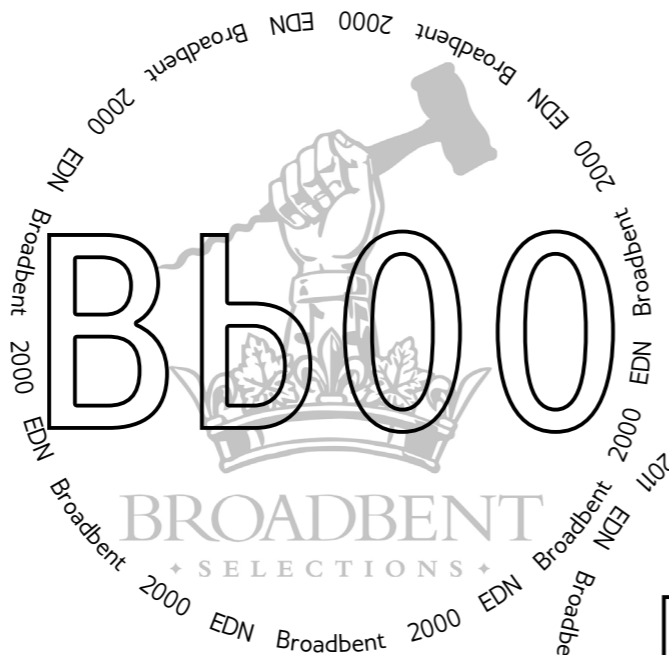

AR

Broadbent Auction Reserve

BROADBENT SELECTIONS

Bb000

Broadbent Auction Reserve

BROADBENT SELECTIONS

Ni11

JDAW Niepoort 2011

F85

JDAW Fonseca 1985

Bb94

Broadbent 1994

BROADBENT SELECTIONS

Bb03

Broadbent 2003

BROADBENT SELECTIONS

Bb11

BROADBENT SELECTIONS

Ps92

Niepoort Quinta do Passadouro 1992

GC83

Could Campbell 1983

Bb97

Broadbent 1997

BROADBENT SELECTIONS

Bb07

Broadbent 2007

BROADBENT SELECTIONS

Bb15

BROADBENT SELECTIONS

W91

Warre 1991

???

"Novelty" AHB



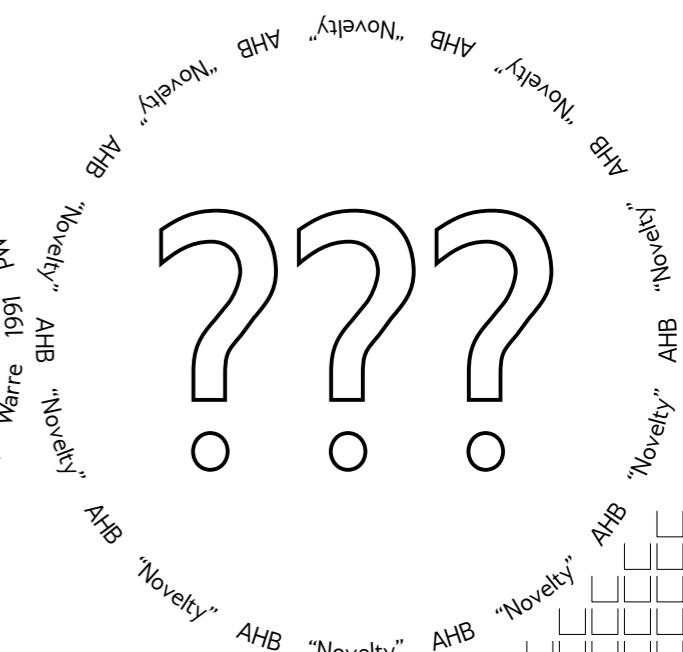
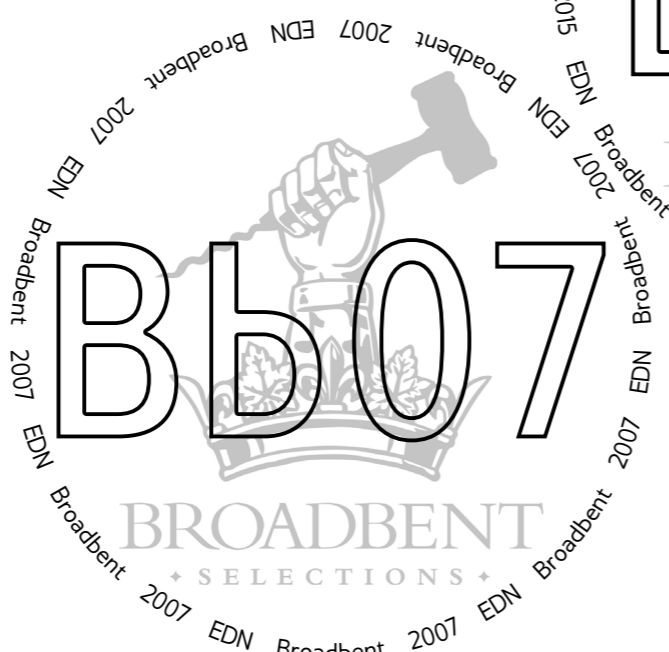
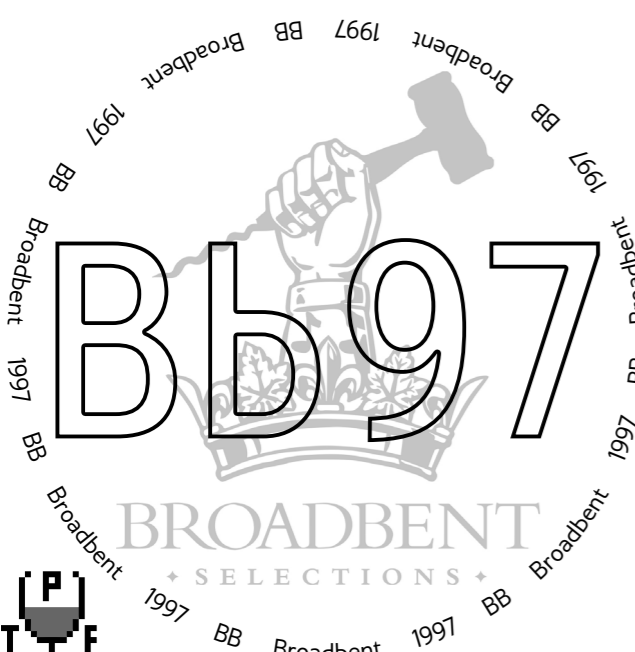
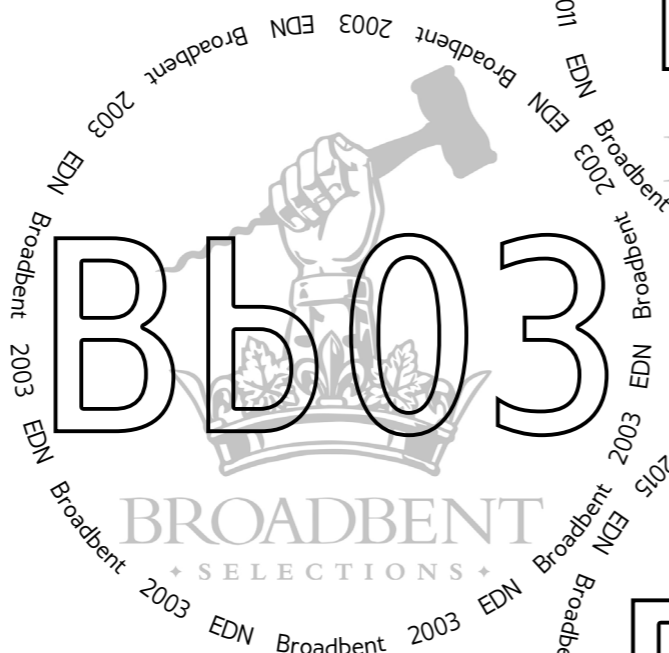
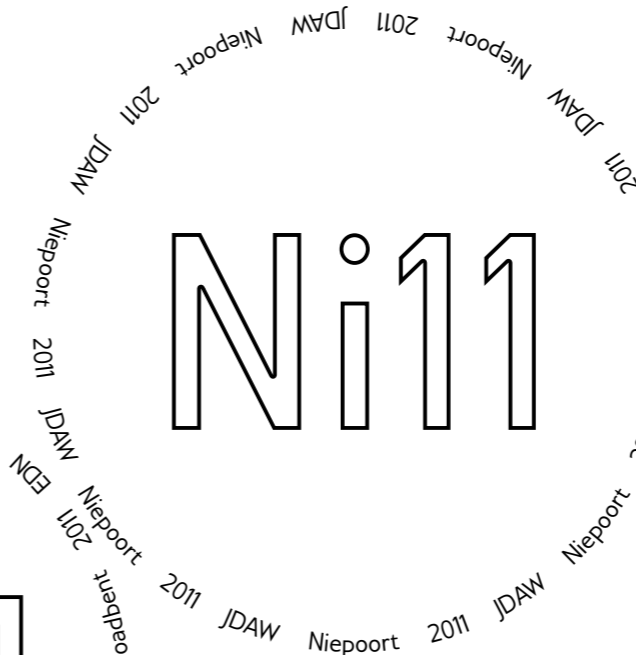
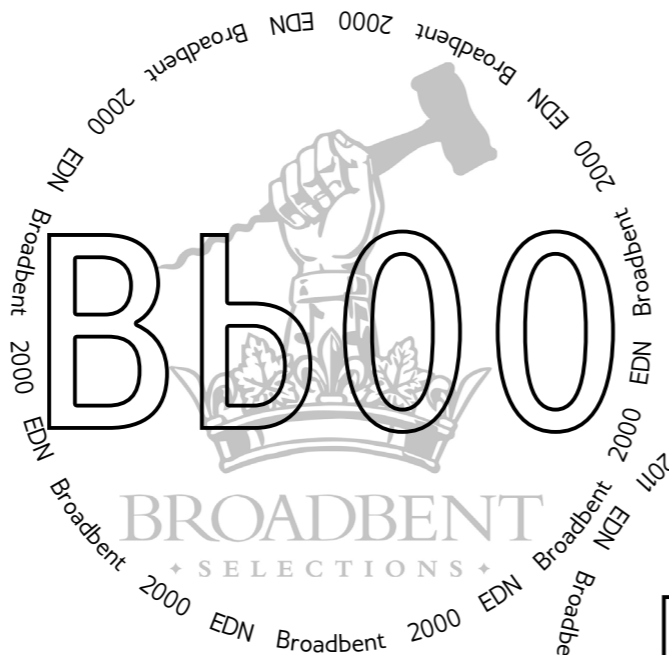

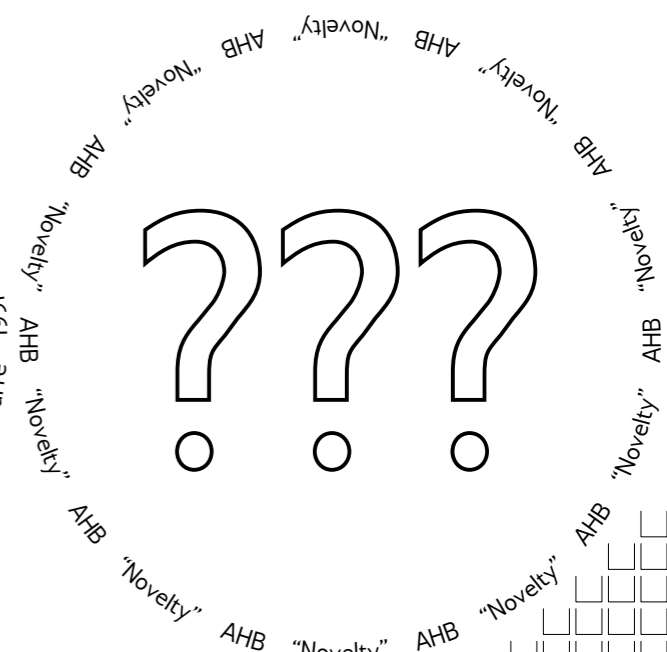
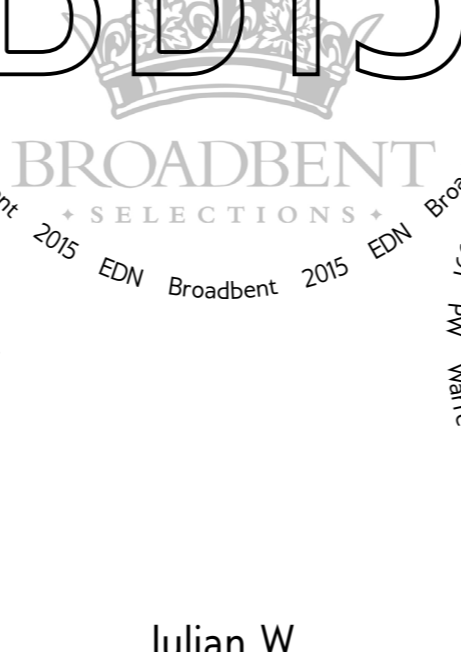
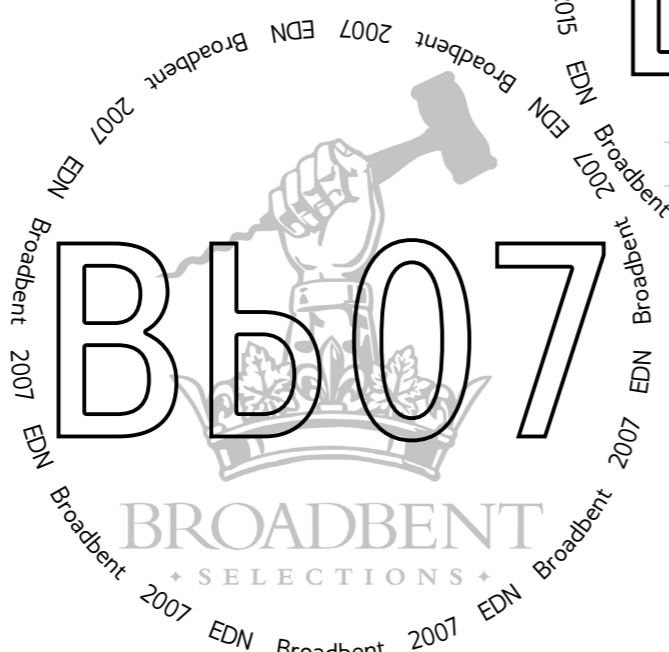
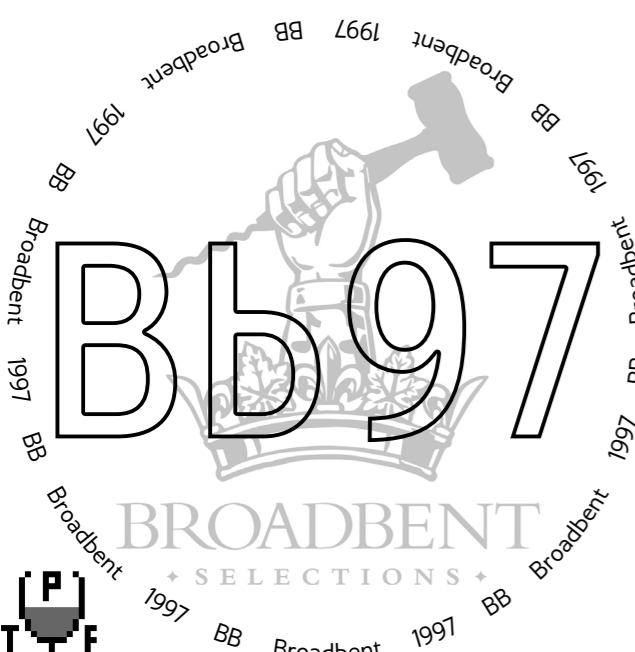
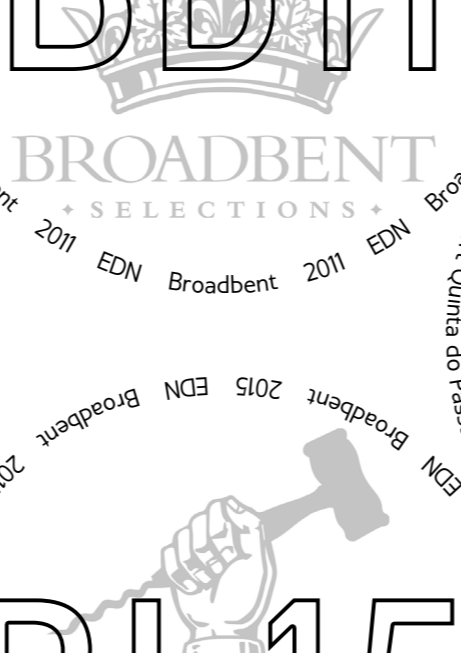
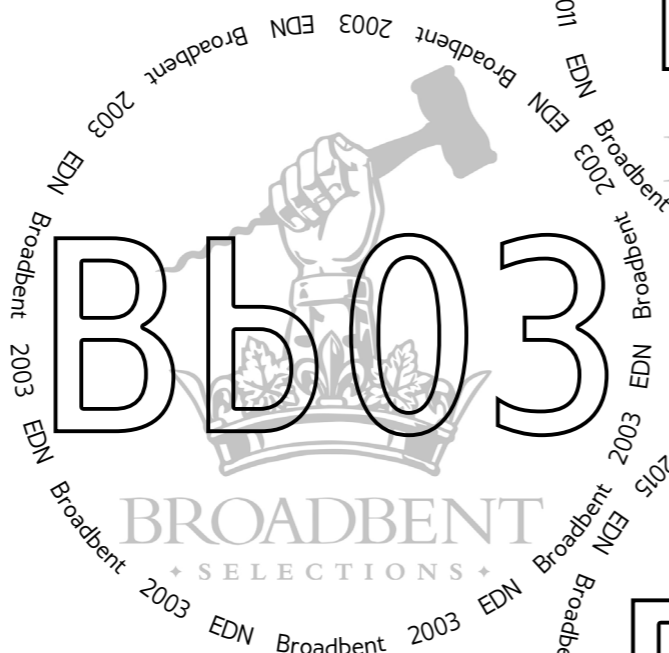
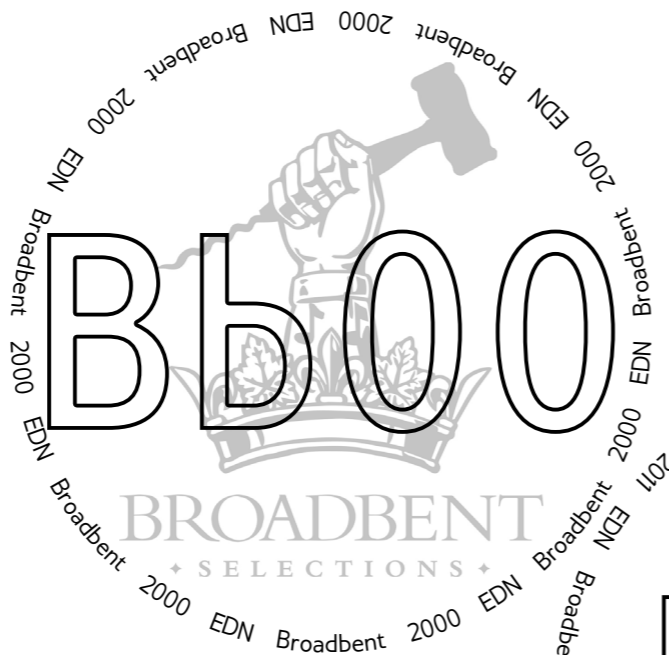

Julian W.

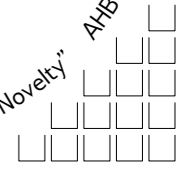

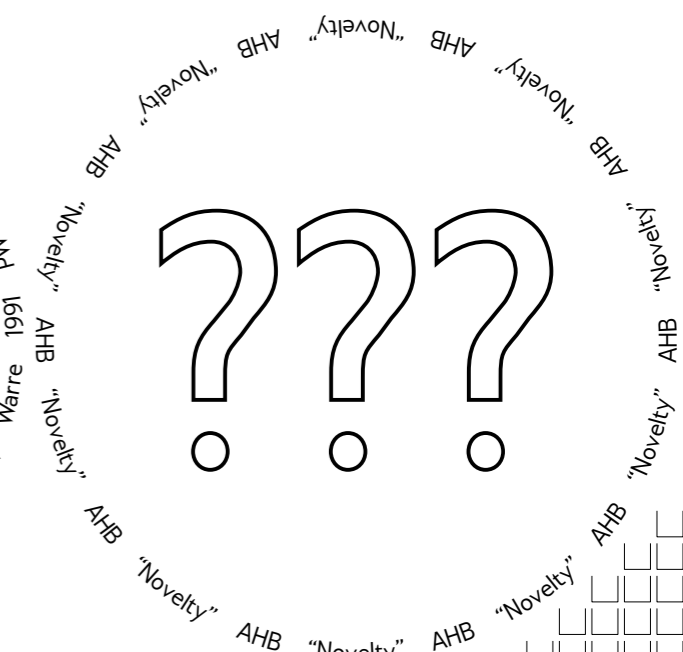
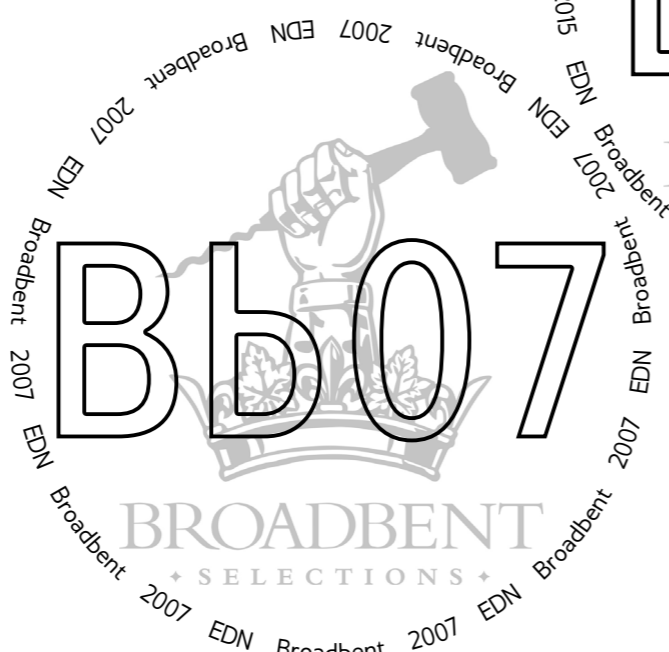
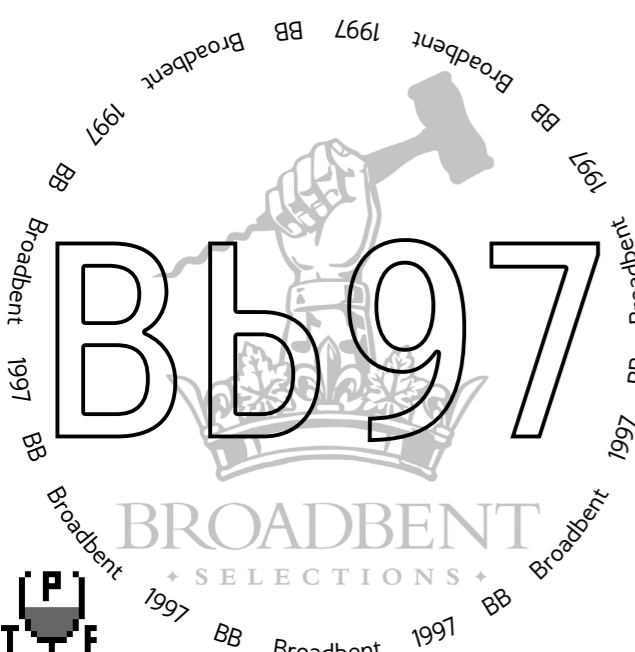
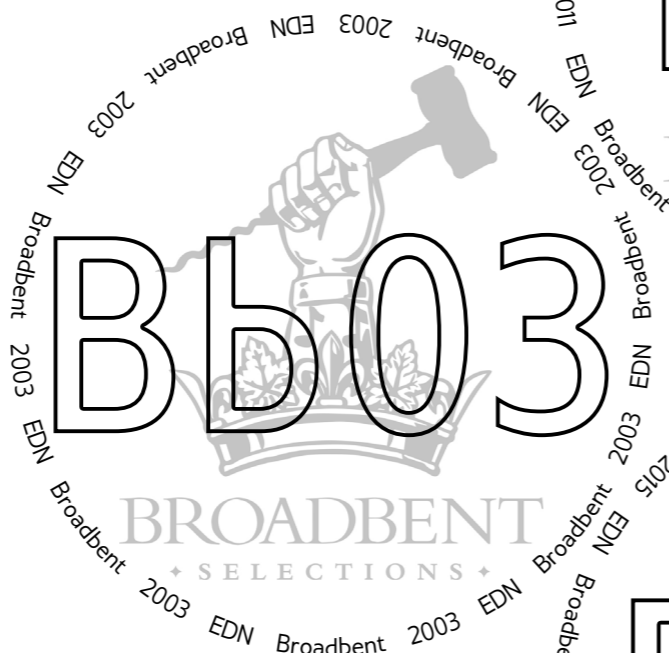
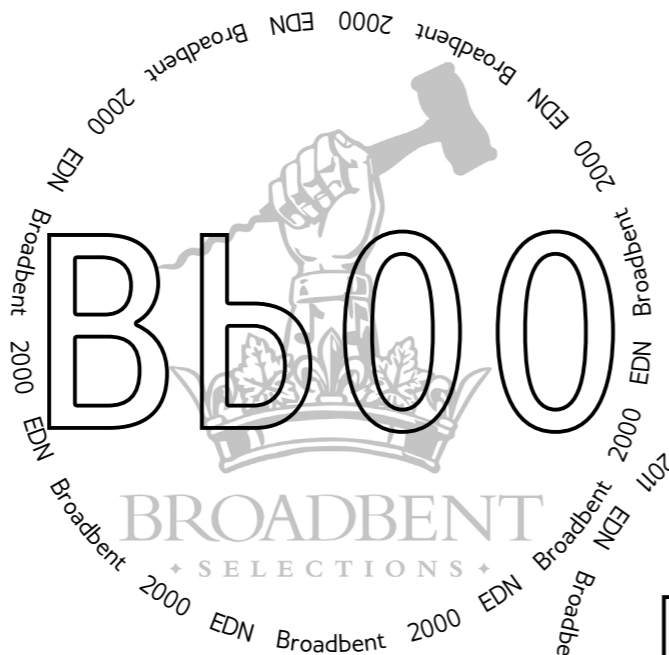

Mike M.



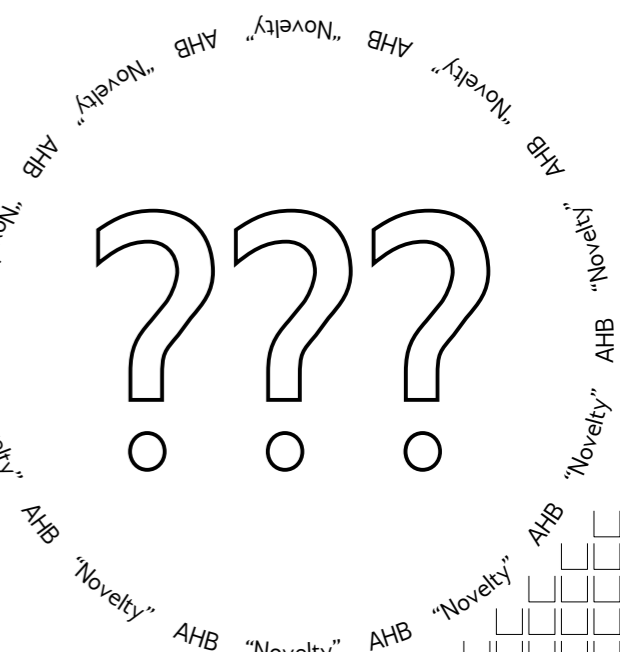
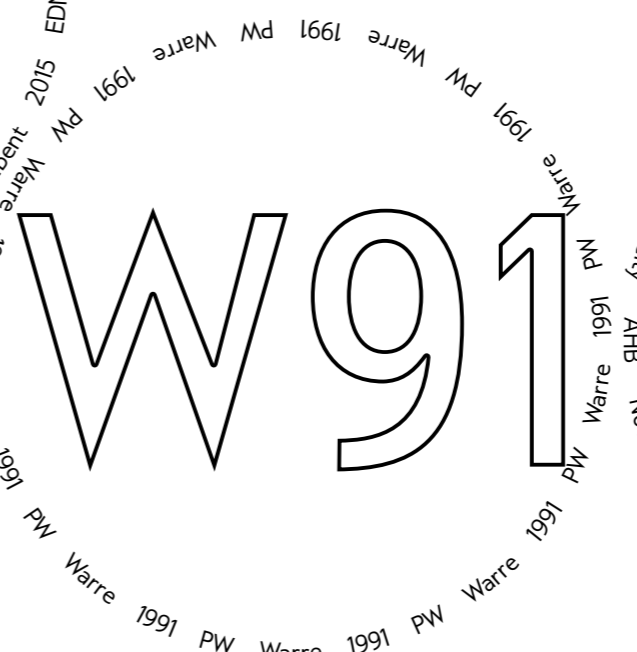
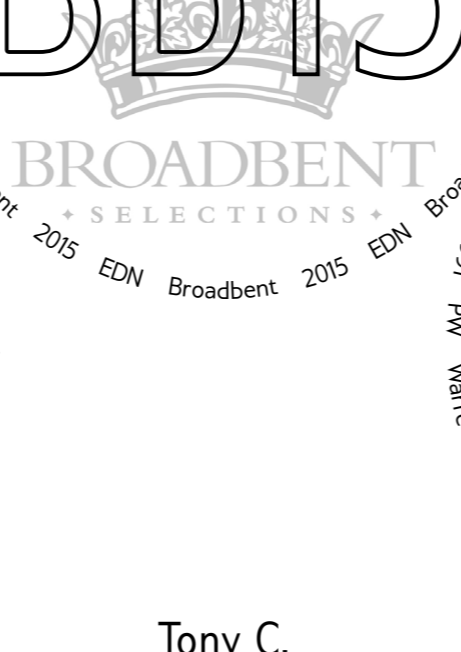
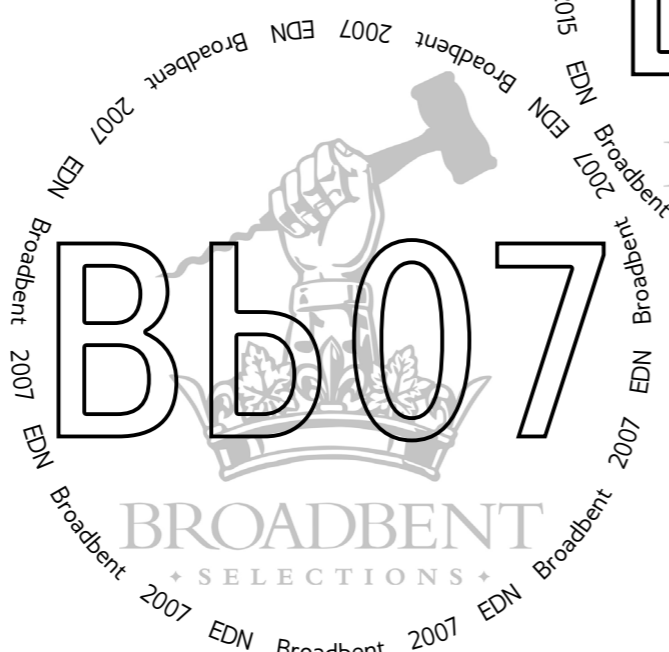
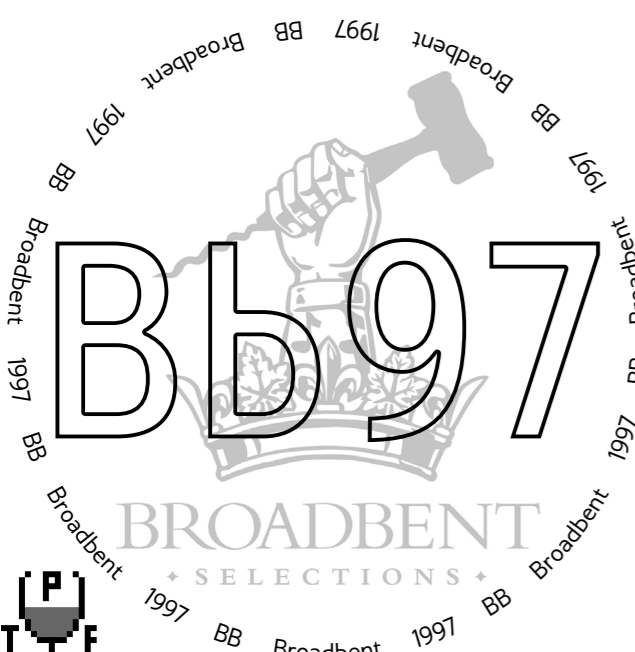
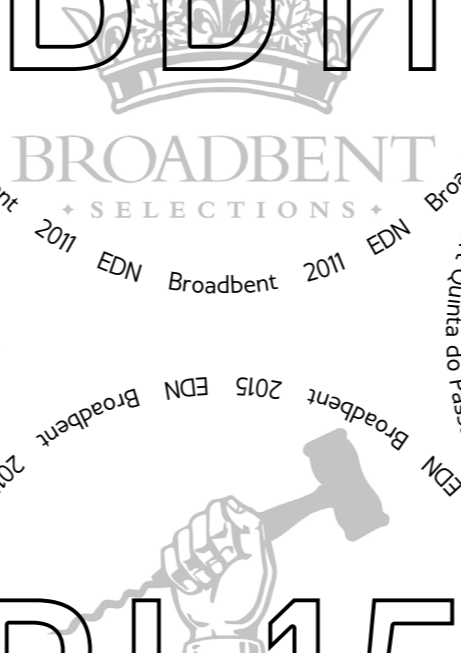
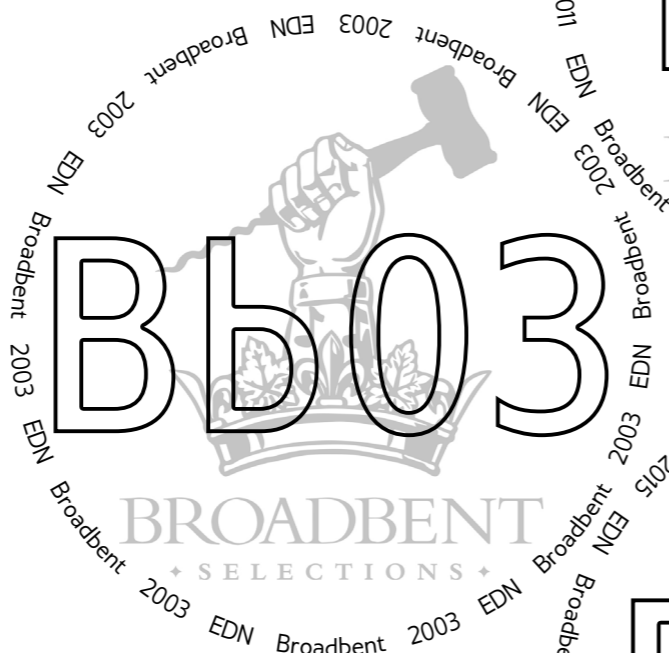
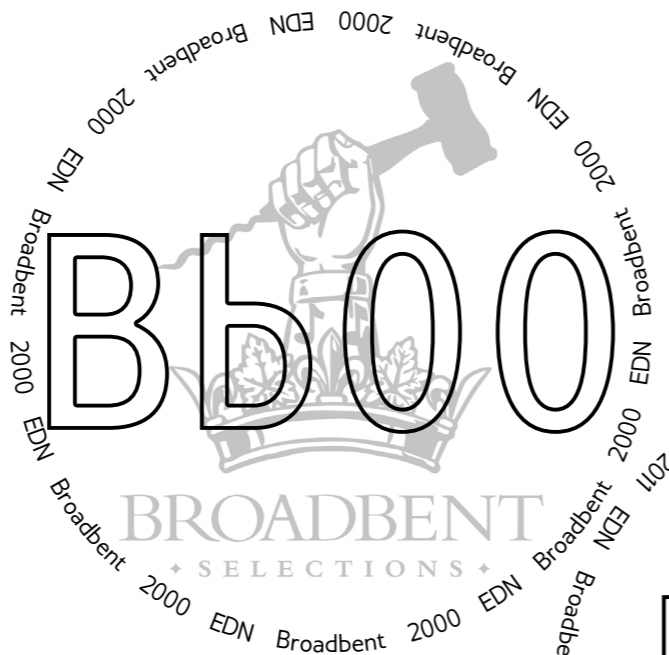

Tony C.



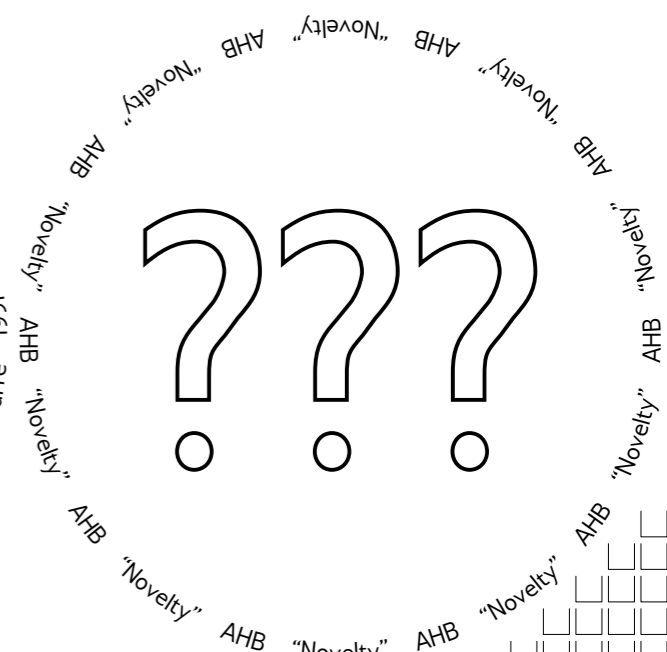
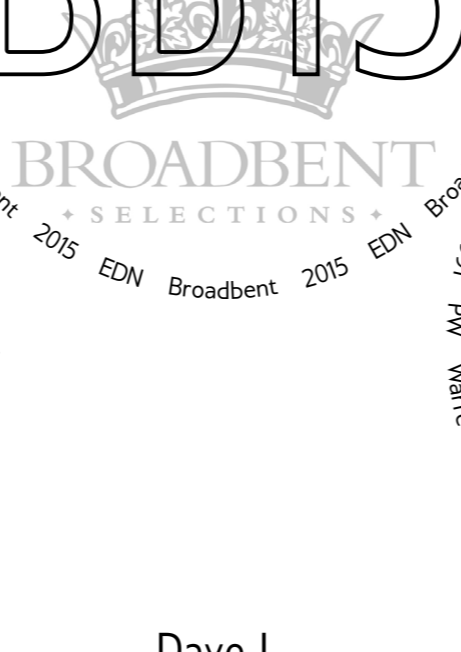
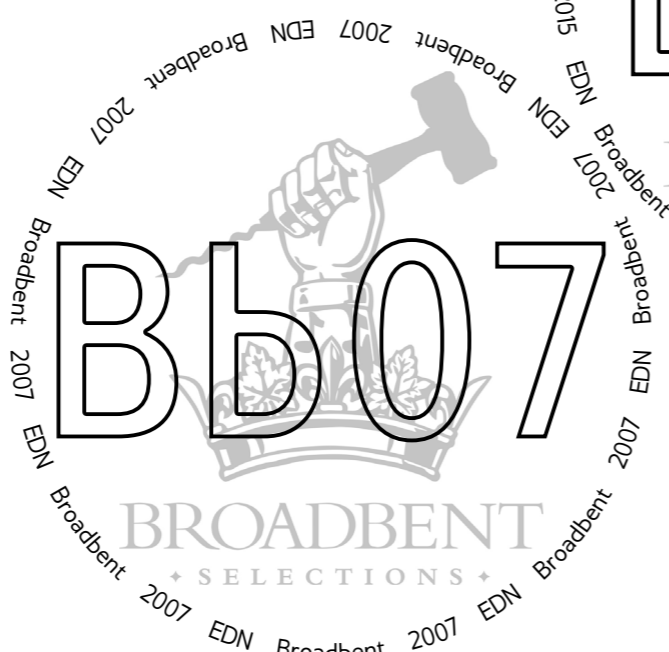
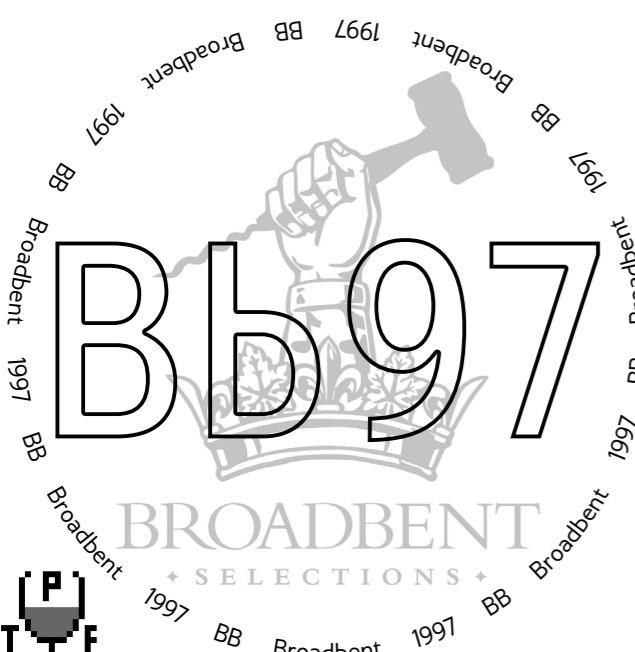
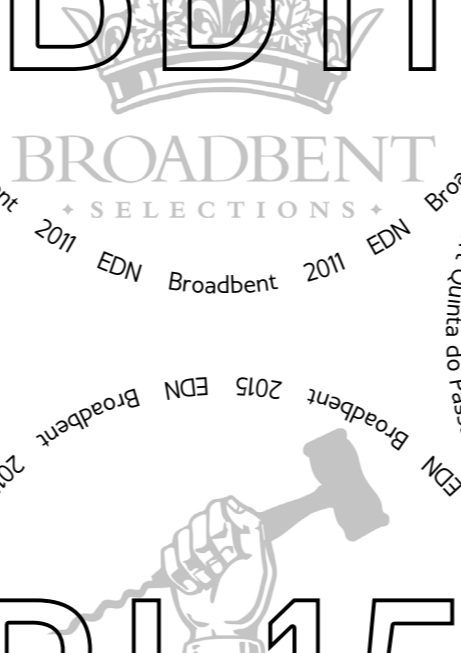
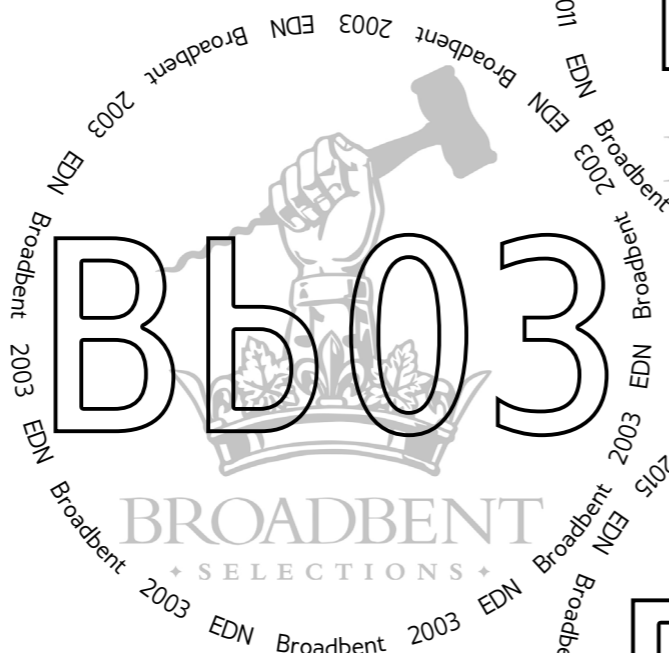
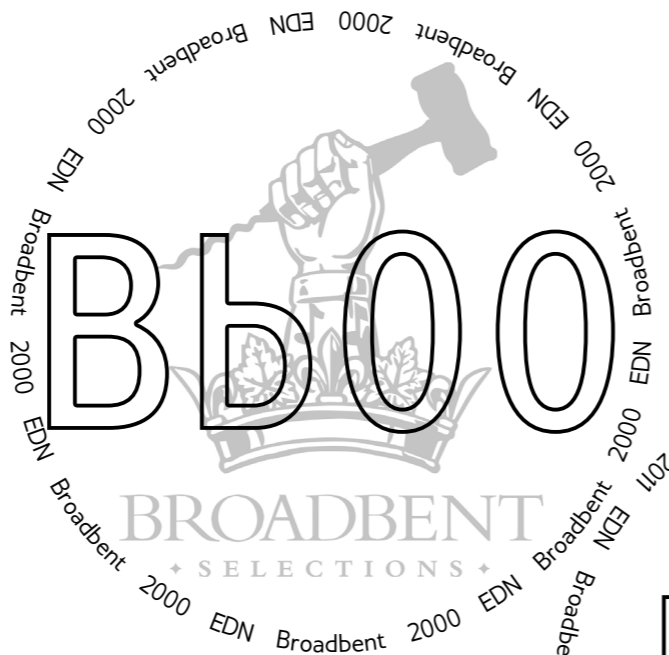

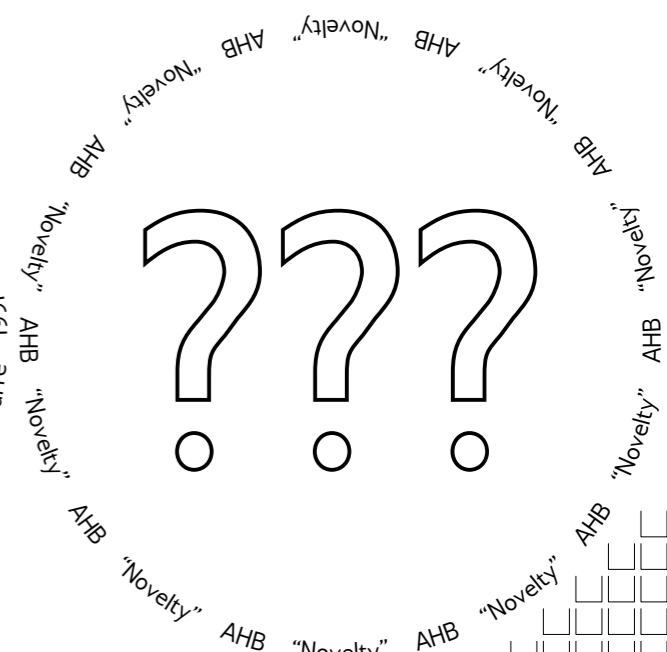
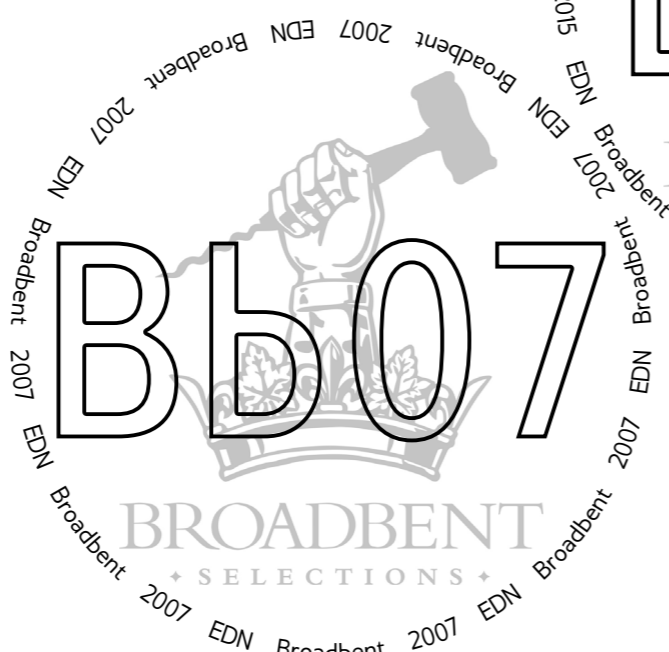
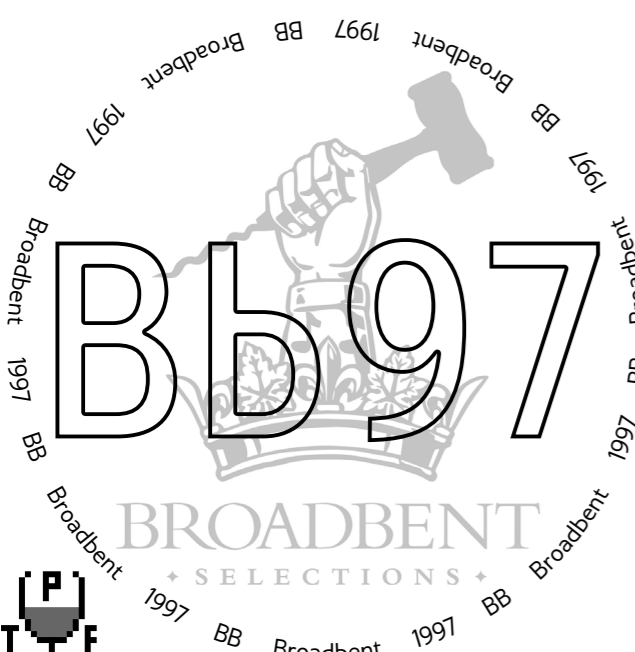
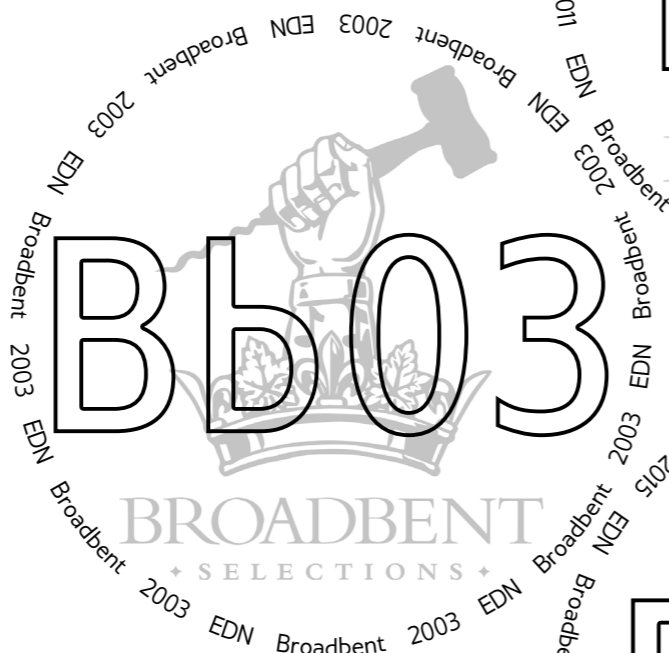
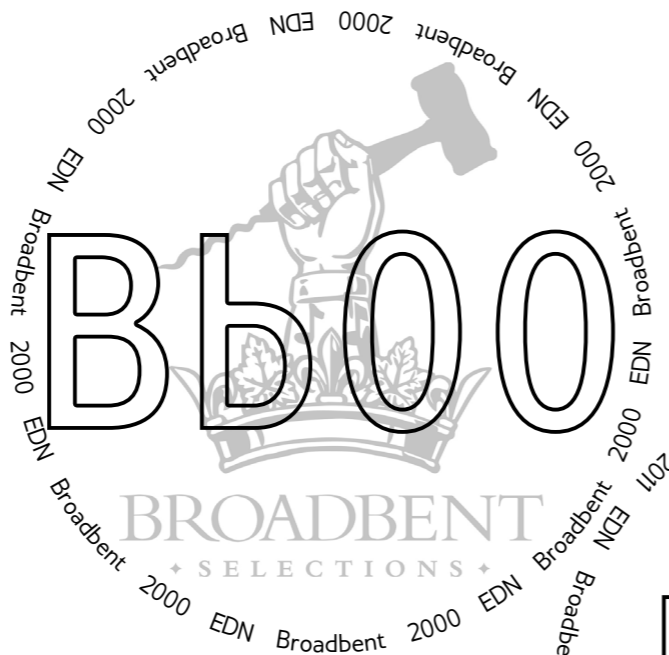

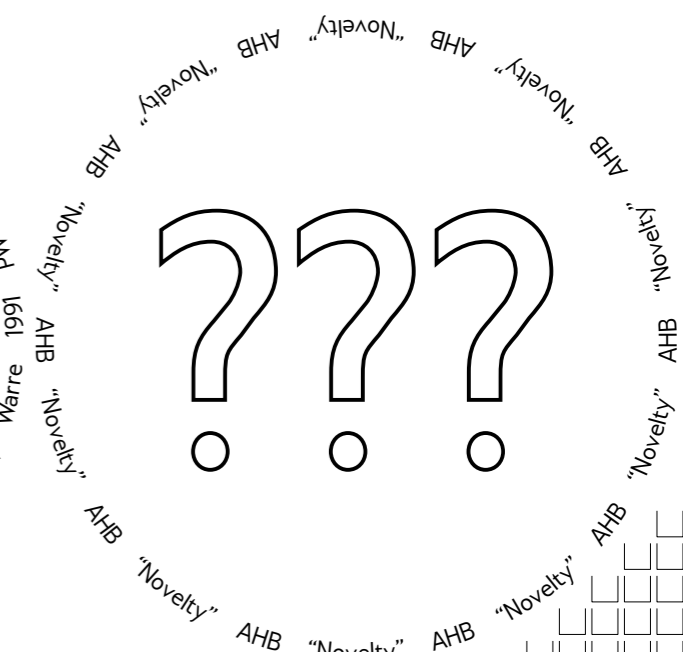
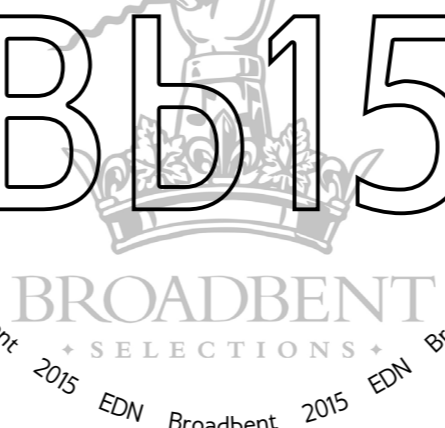
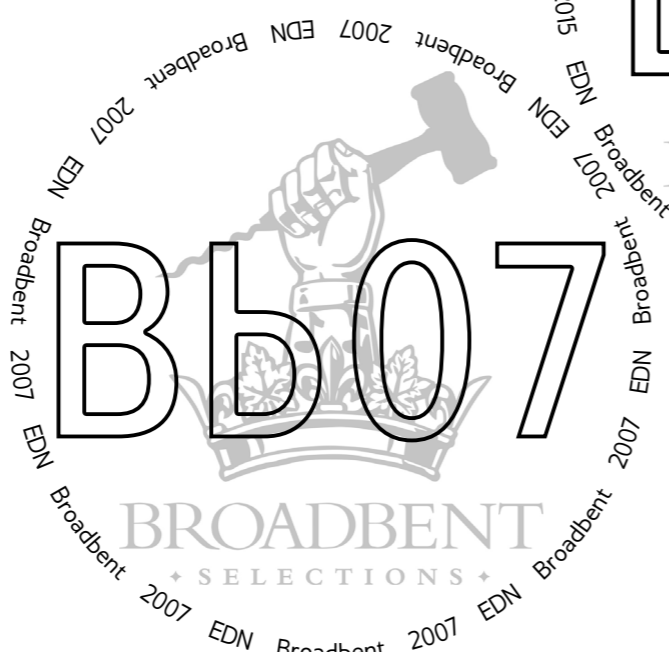
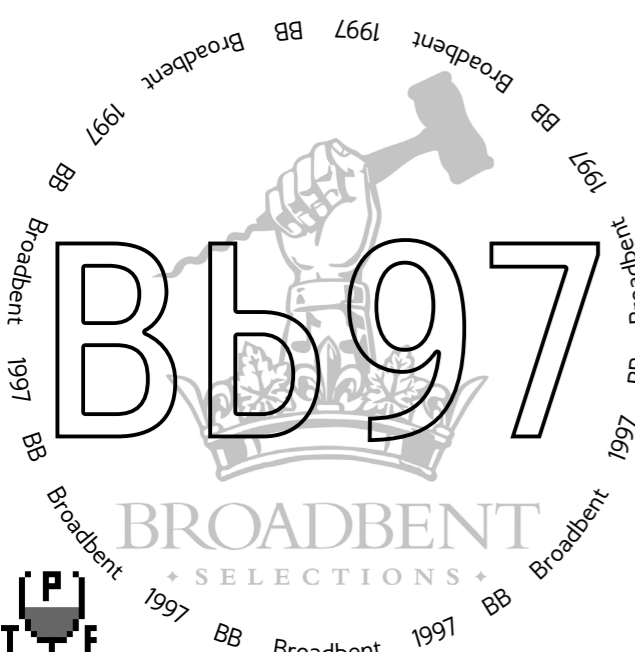
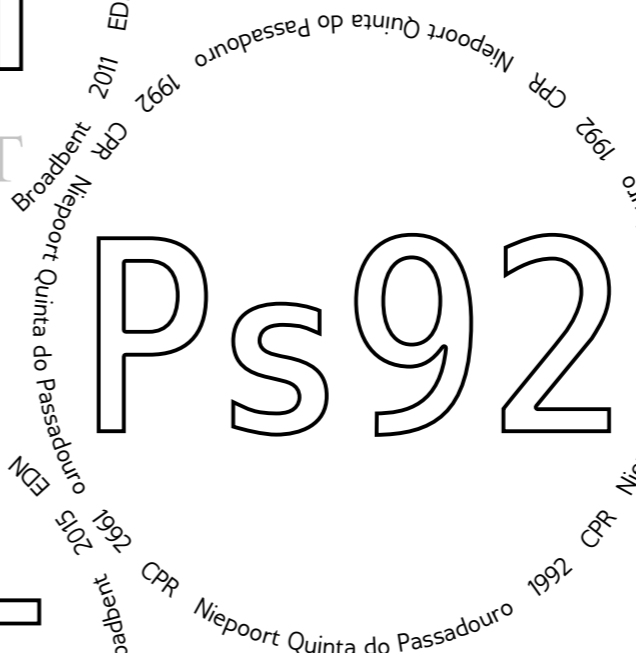
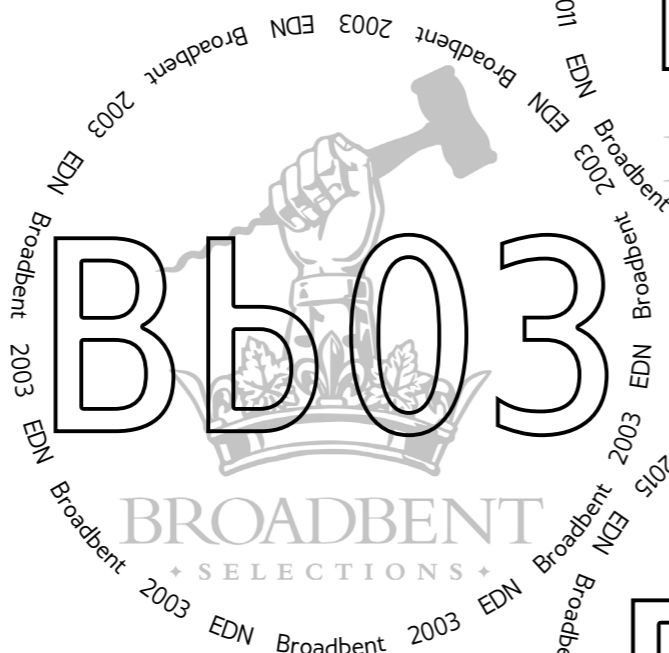
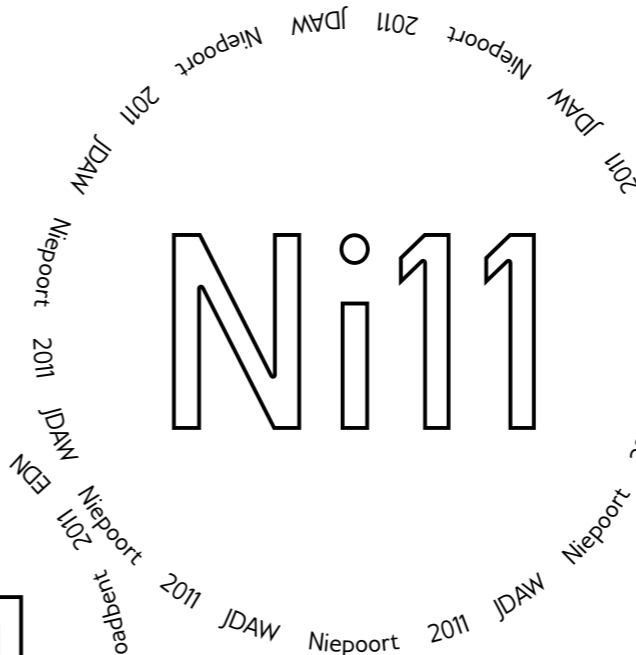
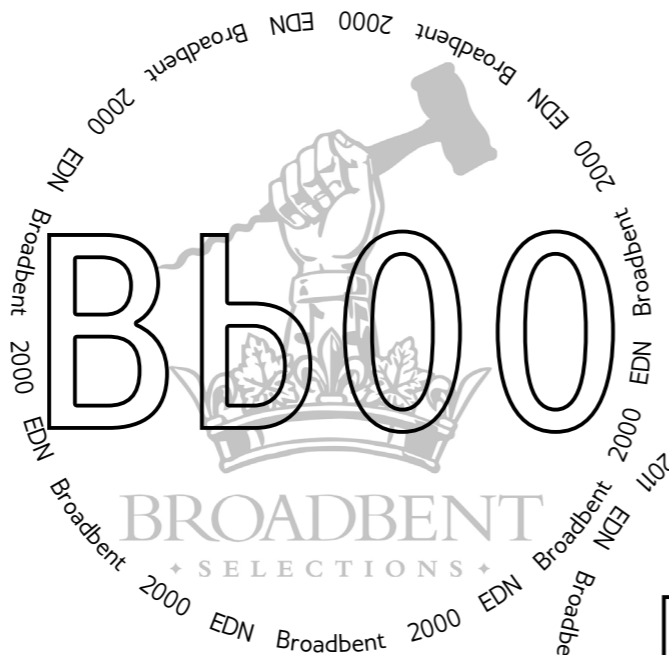

AR

Broadbent Auction Reserve

BROADBENT SELECTIONS

BB

Bb000

Broadbent Auction Reserve

BROADBENT SELECTIONS

EDN Broadbent 2000

Ni11

Niepoort 2011

JDAW

F85

Fonseca 1985

JDAW

Bb94

Broadbent 1994

BROADBENT SELECTIONS

BB

Bb03

Broadbent 2003

BROADBENT SELECTIONS

EDN Broadbent 2003

Bb11

Broadbent 2011

BROADBENT SELECTIONS

EDN Broadbent 2011

Ps92

Niepoort Quinta do Passadouro 1992

CPR

GC83

Could Campbell 1983

MPM

Bb97

Broadbent 1997

BROADBENT SELECTIONS

BB

Bb07

Broadbent 2007

BROADBENT SELECTIONS

EDN Broadbent 2007

Bb15

Broadbent 2015

BROADBENT SELECTIONS

EDN Broadbent 2015

W91

Warre 1991

PW

???

"Novelty" AHB



AR

Broadbent Auction Reserve

BROADBENT SELECTIONS

Bb000

Broadbent 2000 EDN

BROADBENT SELECTIONS

Ni11

JDAW Niepoort 2011

BROADBENT SELECTIONS

F85

JDAW Fonseca 1985

BROADBENT SELECTIONS

Bb94

Broadbent 1994 BB

BROADBENT SELECTIONS

Bb03

Broadbent 2003 EDN

BROADBENT SELECTIONS

Bb11

Broadbent 2011 EDN

BROADBENT SELECTIONS

Ps92

Niepoort Quinta do Passadouro 1992 CPR

BROADBENT SELECTIONS

GC83

Could Campbell 1983 MPM

BROADBENT SELECTIONS

Bb97

Broadbent 1997 BB

BROADBENT SELECTIONS

Bb07

Broadbent 2007 EDN

BROADBENT SELECTIONS

Bb15

Broadbent 2015 EDN

BROADBENT SELECTIONS

W91

Warre 1991 PW

BROADBENT SELECTIONS

???

"Novelty" AHB

BROADBENT SELECTIONS



AR

Broadbent Auction Reserve

BROADBENT SELECTIONS

BB

Bb000

Broadbent 2000 EDN

BROADBENT SELECTIONS

BB

Ni11

JDAW Niepoort 2011

BROADBENT SELECTIONS

BB

F85

JDAW Fonseca 1985

BROADBENT SELECTIONS

BB

Bb94

Broadbent 1994 BB

BROADBENT SELECTIONS

BB

Bb03

Broadbent 2003 EDN

BROADBENT SELECTIONS

BB

Bb11

Broadbent 2011 EDN

BROADBENT SELECTIONS

BB

Ps92

Niepoort Quinta do Passadouro 1992 CPR

BROADBENT SELECTIONS

BB

GC83

Could Campbell 1983 MPM

BROADBENT SELECTIONS

BB

Bb97

Broadbent 1997 BB

BROADBENT SELECTIONS

BB

Bb07

Broadbent 2007 EDN

BROADBENT SELECTIONS

BB

Bb15

Broadbent 2015 EDN

BROADBENT SELECTIONS

BB

W91

Warre 1991 PW

BROADBENT SELECTIONS

BB

???

"Novelty" AHB

BROADBENT SELECTIONS

BB



Times Eye Nose Mouth Score  
Broadbent Auction Reserve BB Broadbent Auction Reserve BB Broadbent Auction Reserve BB Broadbent Auction Reserve BB Broadbent Auction Reserve BB Broadbent Auction Reserve BB Broadbent Auction Reserve BB Broadbent Auction Reserve BB Broadbent Auction Reserve BB

# Bb Auction Reserve



# Bb1994

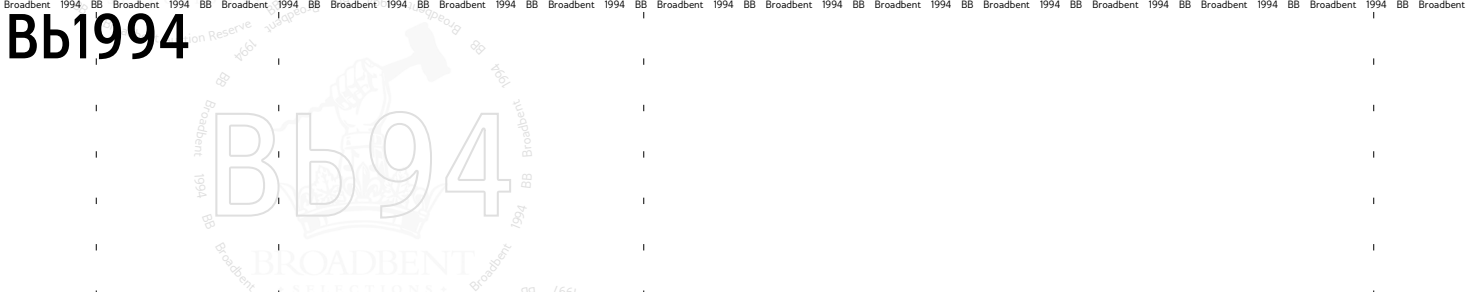

# Bb1997

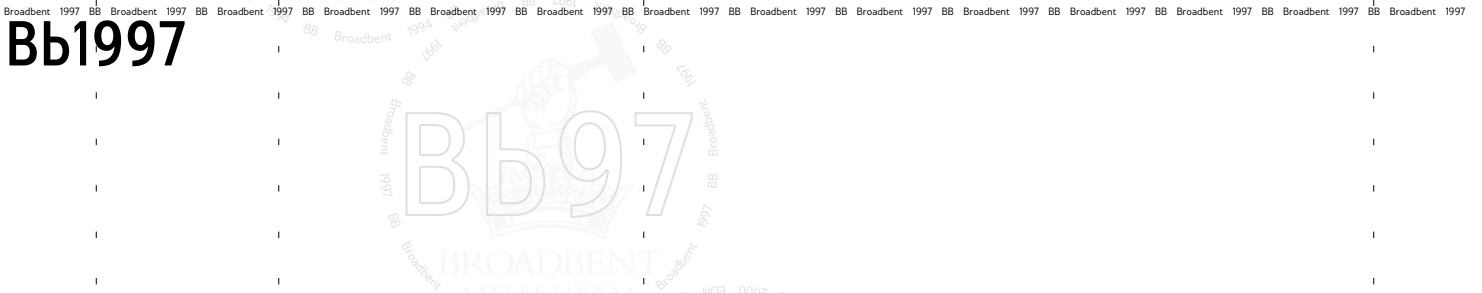

# Bb2002

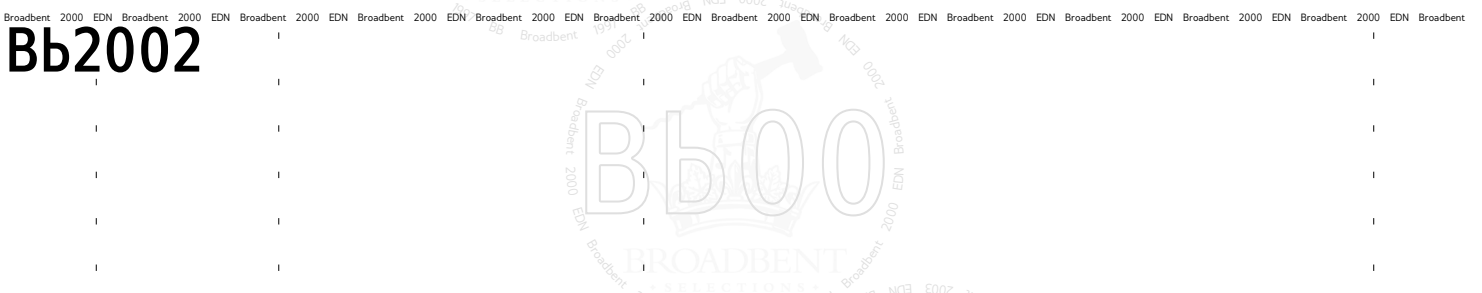

# Bb2005

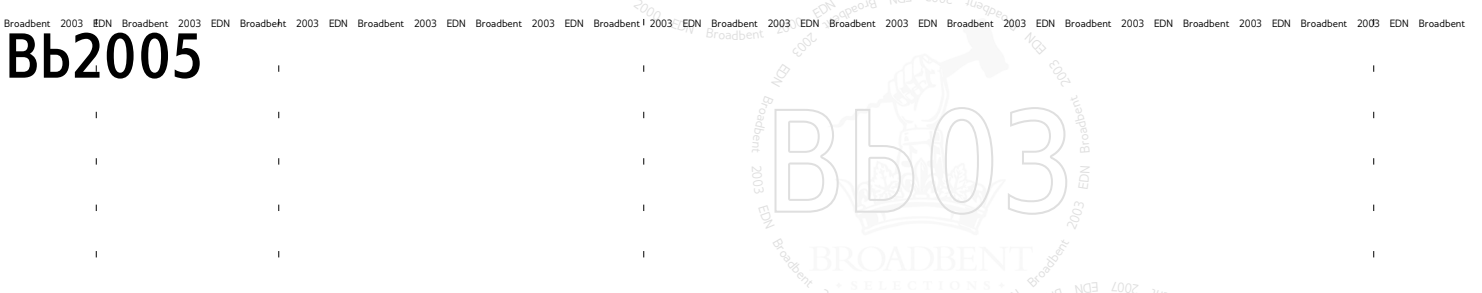

# Bb2007

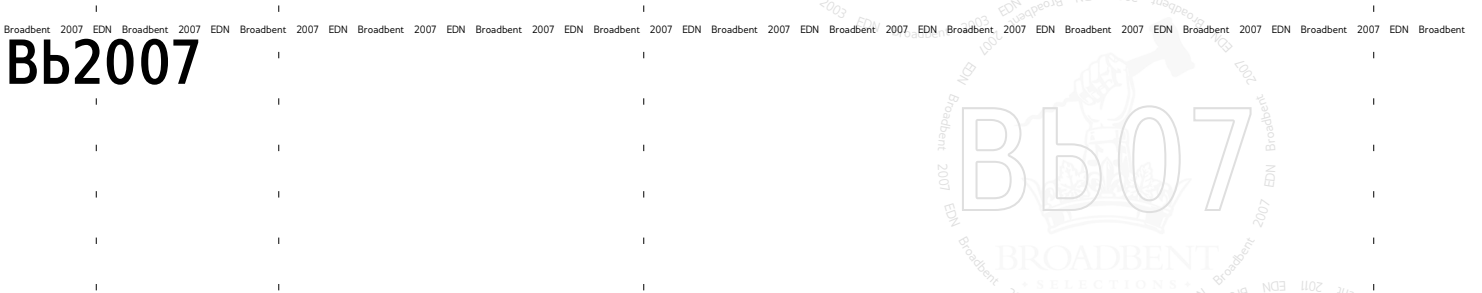

# Bb2011

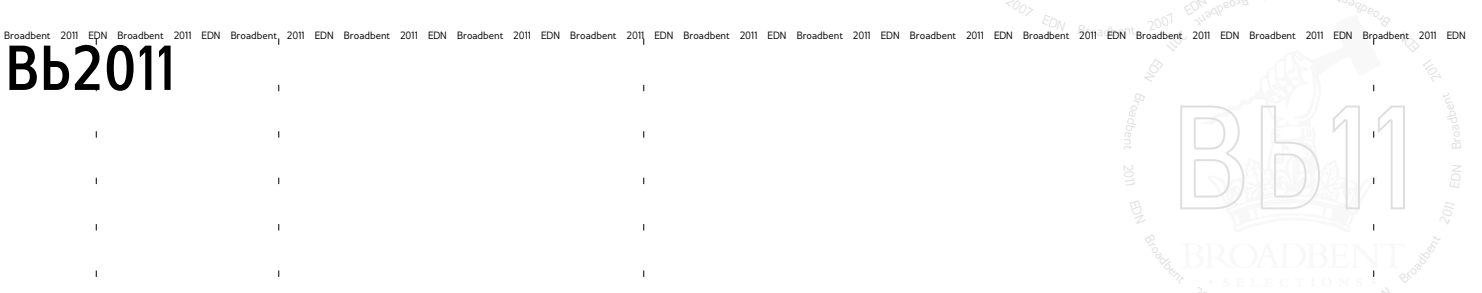



Times Eye Nose Mouth Score  
Broadbent 2015 EDN Broadbent 2015 EDN Broadbent 2015 EDN Broadbent 2015 EDN Broadbent 2015 EDN Broadbent 2015 EDN Broadbent 2015 EDN Broadbent 2015 EDN Broadbent 2015 EDN Broadbent 2015 EDN Broadbent 2015 EDN Broadbent 2015 EDN Broadbent 2015 EDN Broadbent 2015 EDN Broadbent 2015 EDN Broadbent 2015 EDN Broadbent 2015 EDN

# Bb2015



# Ni2011



# Ps1992



# W1991



# F1985



# Gc1983



# ???



# Bb Auction Reserve

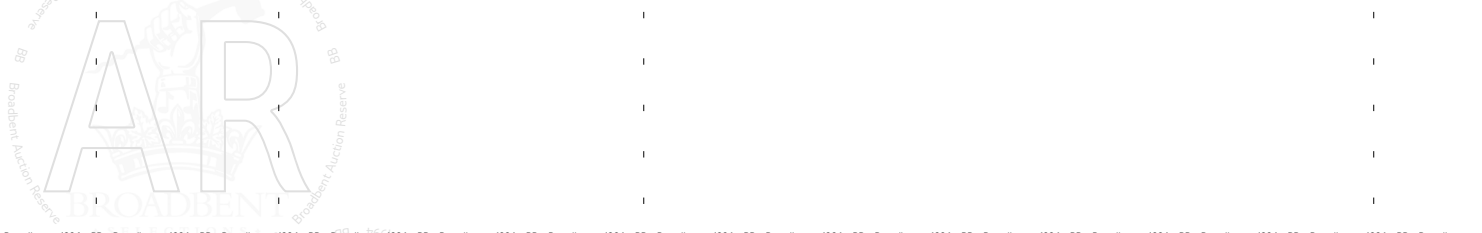

# Bb1994

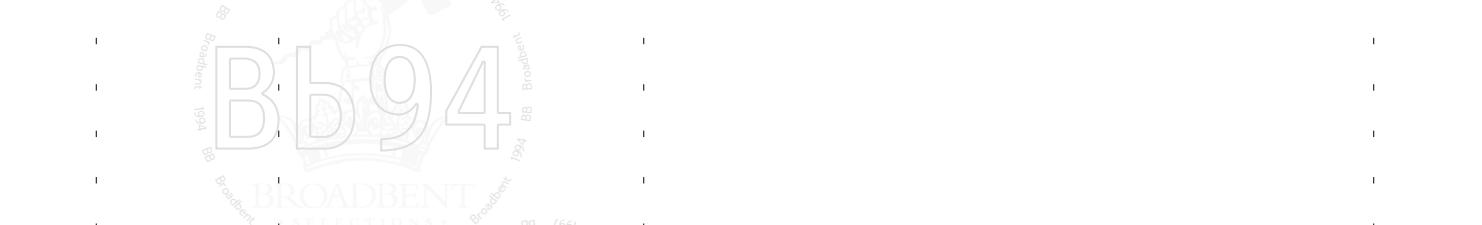

# Bb1997



# Bb2002

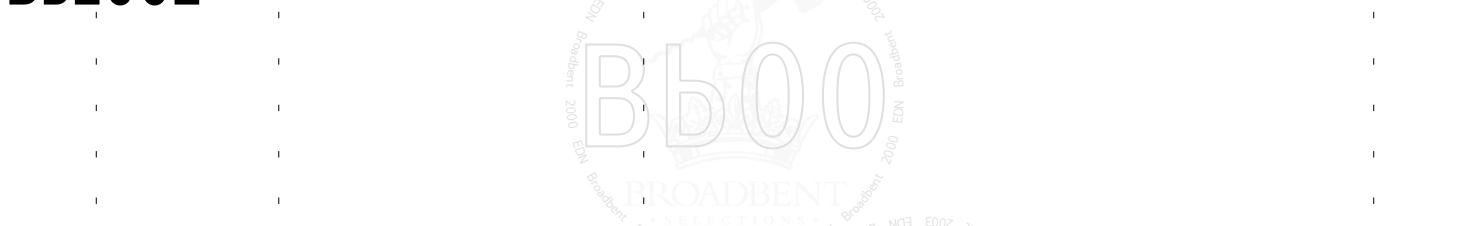

# Bb2003



# Bb2007



# Bb2011

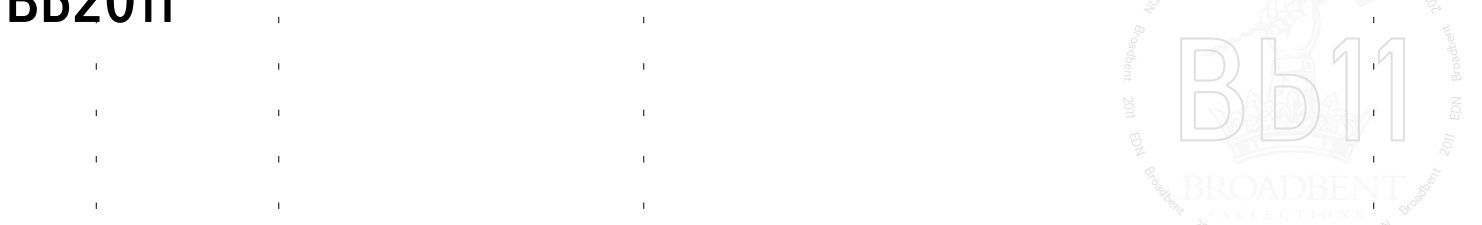



Times Eye Nose Mouth Score  
Broadbent Auction Reserve BB Broadbent Auction Reserve BB Broadbent Auction Reserve BB Broadbent Auction Reserve BB Broadbent Auction Reserve BB Broadbent Auction Reserve BB Broadbent Auction Reserve BB Broadbent Auction Reserve BB Broadbent Auction Reserve BB

# Bb Auction Reserve



# Bb1994

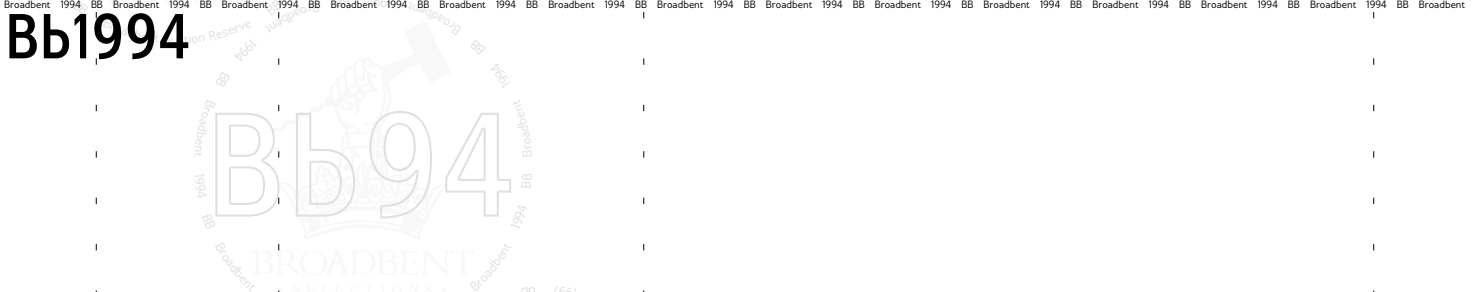

# Bb1997

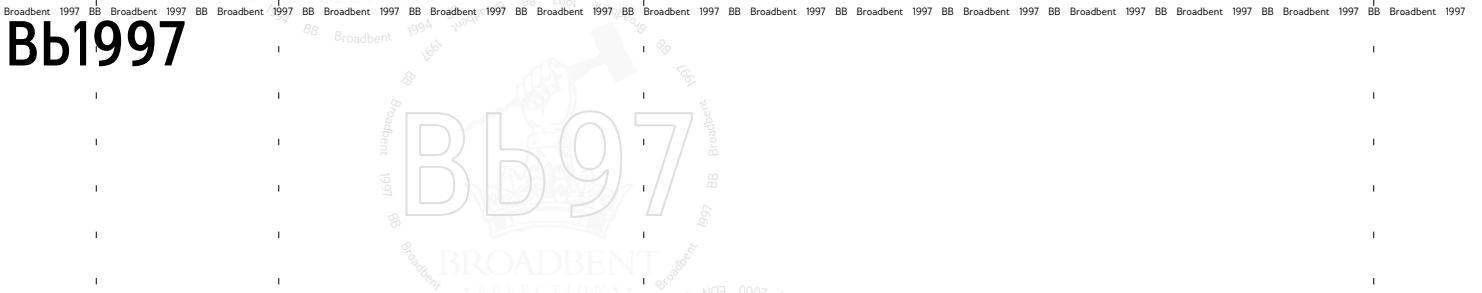

# Bb2002

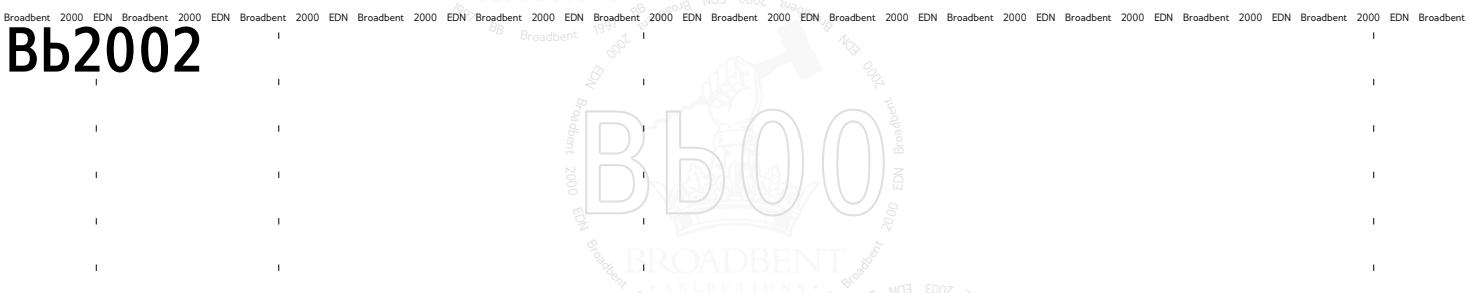

# Bb2005

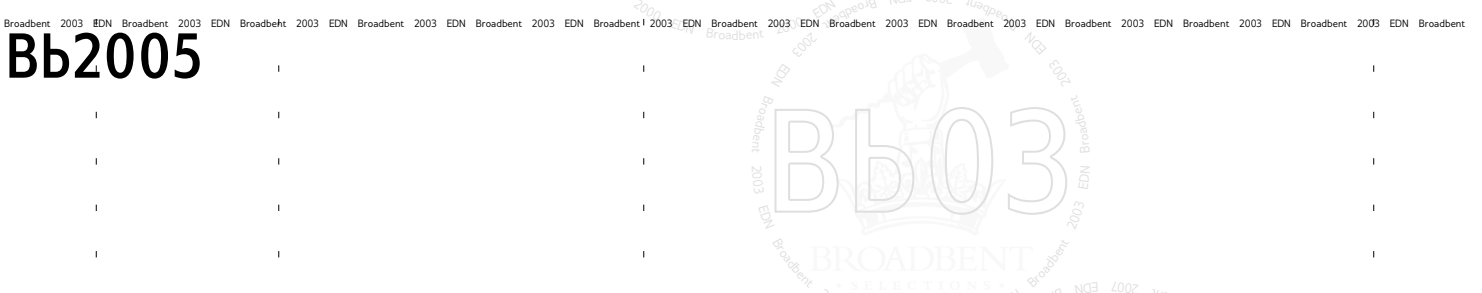

# Bb2007

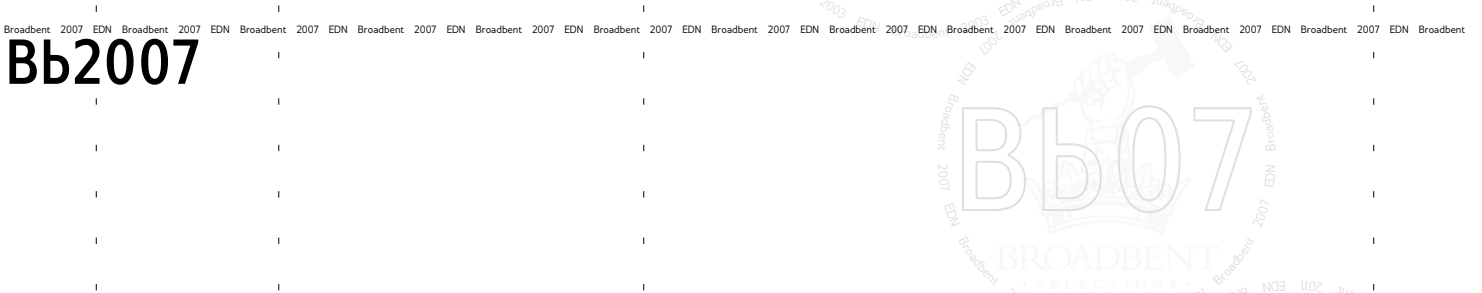

# Bb2011

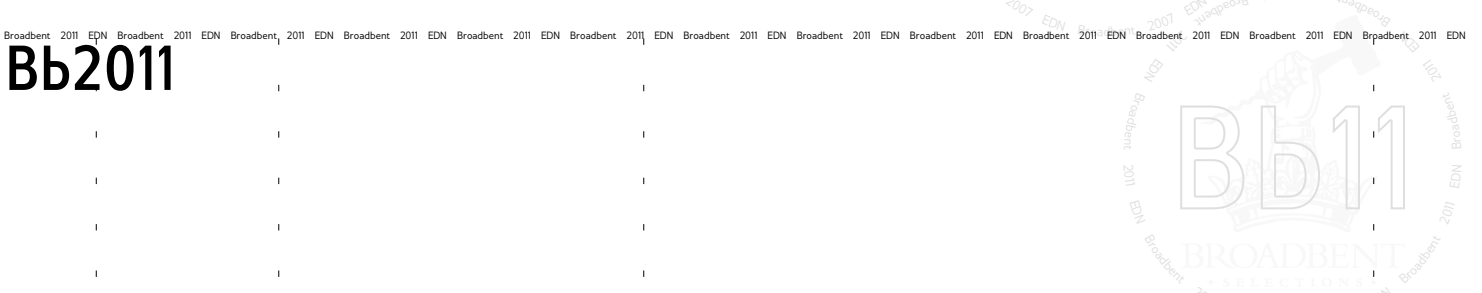



# Bb Auction Reserve



## Bb1994



## Bb1997



## Bb2002

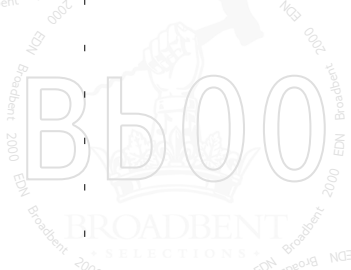

## Bb2003



## Bb2007

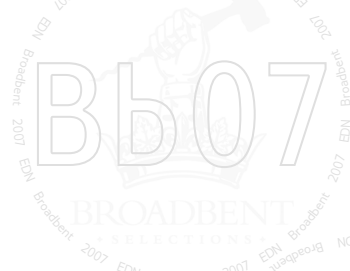

## Bb2011



Jörgen B.

Times			Eye			Nose			Mouth			Score																	
Broadbent	2015	EDN	Broadbent	2015	EDN	Broadbent	2015	EDN	Broadbent	2015	EDN	Broadbent	2015	EDN	Broadbent	2015	EDN	Broadbent	2015	EDN	Broadbent	2015	EDN	Broadbent	2015	EDN	Broadbent	2015	EDN

# Bb2015

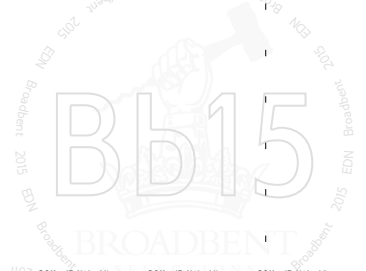

Times			Eye			Nose			Mouth			Score																	
Broadbent	2015	EDN	Broadbent	2015	EDN	Broadbent	2015	EDN	Broadbent	2015	EDN	Broadbent	2015	EDN	Broadbent	2015	EDN	Broadbent	2015	EDN	Broadbent	2015	EDN	Broadbent	2015	EDN	Broadbent	2015	EDN

# Ni2011



Times			Eye			Nose			Mouth			Score																	
Broadbent	2015	EDN	Broadbent	2015	EDN	Broadbent	2015	EDN	Broadbent	2015	EDN	Broadbent	2015	EDN	Broadbent	2015	EDN	Broadbent	2015	EDN	Broadbent	2015	EDN	Broadbent	2015	EDN	Broadbent	2015	EDN

# Ps1992



Times			Eye			Nose			Mouth			Score																	
Broadbent	2015	EDN	Broadbent	2015	EDN	Broadbent	2015	EDN	Broadbent	2015	EDN	Broadbent	2015	EDN	Broadbent	2015	EDN	Broadbent	2015	EDN	Broadbent	2015	EDN	Broadbent	2015	EDN	Broadbent	2015	EDN

# W1991



Times			Eye			Nose			Mouth			Score																	
Broadbent	2015	EDN	Broadbent	2015	EDN	Broadbent	2015	EDN	Broadbent	2015	EDN	Broadbent	2015	EDN	Broadbent	2015	EDN	Broadbent	2015	EDN	Broadbent	2015	EDN	Broadbent	2015	EDN	Broadbent	2015	EDN

# F1985



Times			Eye			Nose			Mouth			Score																	
Broadbent	2015	EDN	Broadbent	2015	EDN	Broadbent	2015	EDN	Broadbent	2015	EDN	Broadbent	2015	EDN	Broadbent	2015	EDN	Broadbent	2015	EDN	Broadbent	2015	EDN	Broadbent	2015	EDN	Broadbent	2015	EDN

# Gc1983



Times			Eye			Nose			Mouth			Score																	
Broadbent	2015	EDN	Broadbent	2015	EDN	Broadbent	2015	EDN	Broadbent	2015	EDN	Broadbent	2015	EDN	Broadbent	2015	EDN	Broadbent	2015	EDN	Broadbent	2015	EDN	Broadbent	2015	EDN	Broadbent	2015	EDN

# ???

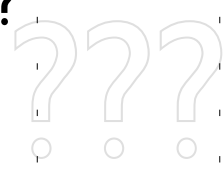





Times				Eye				Nose				Mouth				Score			
Broadbent	2015	EDN	Broadbent	2015	EDN	Broadbent	2015	EDN	Broadbent	2015	EDN	Broadbent	2015	EDN	Broadbent	2015	EDN	Broadbent	

# Bb2015

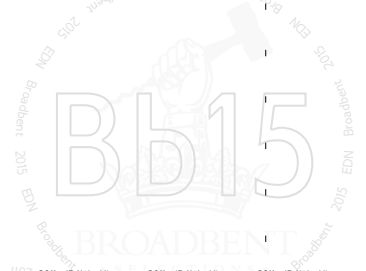

Niepoort				JDAW				Niepoort				JDAW				Niepoort				JDAW				Niepoort							
2011	JDAW	2011	JDAW	2011	JDAW	2011	JDAW	2011	JDAW	2011	JDAW	2011	JDAW	2011	JDAW	2011	JDAW	2011	JDAW	2011	JDAW	2011	JDAW	2011	JDAW	2011	JDAW	2011	JDAW	2011	JDAW

# Ni2011

# Ni11

Niepoort Quinta do Passadouro				CPR				Niepoort Quinta do Passadouro				CPR				Niepoort Quinta do Passadouro				CPR											
1992	CPR	1992	CPR	1992	CPR	1992	CPR	1992	CPR	1992	CPR	1992	CPR	1992	CPR	1992	CPR	1992	CPR	1992	CPR	1992	CPR	1992	CPR	1992	CPR	1992	CPR	1992	CPR

# Ps1992

# Ps92

Warre				PW				Warre				PW				Warre				PW				Warre				PW			
1991	PW	1991	PW	1991	PW	1991	PW	1991	PW	1991	PW	1991	PW	1991	PW	1991	PW	1991	PW	1991	PW	1991	PW	1991	PW	1991	PW	1991	PW	1991	PW

# W1991

# W91

Fonseca				JDAW				Fonseca				JDAW				Fonseca				JDAW				Fonseca				JDAW			
1985	JDAW	1985	JDAW	1985	JDAW	1985	JDAW	1985	JDAW	1985	JDAW	1985	JDAW	1985	JDAW	1985	JDAW	1985	JDAW	1985	JDAW	1985	JDAW	1985	JDAW	1985	JDAW	1985	JDAW	1985	JDAW

# F1985

# F85

Could Campbell				MPM				Could Campbell				MPM				Could Campbell				MPM				Could Campbell				MPM			
1983	MPM	1983	MPM	1983	MPM	1983	MPM	1983	MPM	1983	MPM	1983	MPM	1983	MPM	1983	MPM	1983	MPM	1983	MPM	1983	MPM	1983	MPM	1983	MPM	1983	MPM	1983	MPM

# Gc1983

# GC83

Novelty				AHB				Novelty				AHB				Novelty				AHB				Novelty				AHB			
1983	AHB	1983	AHB	1983	AHB	1983	AHB	1983	AHB	1983	AHB	1983	AHB	1983	AHB	1983	AHB	1983	AHB	1983	AHB	1983	AHB	1983	AHB	1983	AHB	1983	AHB	1983	AHB

# ???

# ???



# Bb Auction Reserve



## Bb1994



## Bb1997

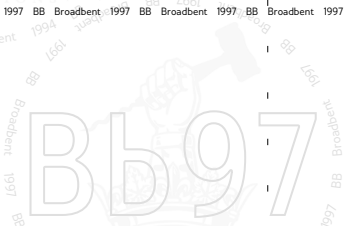

## Bb2002

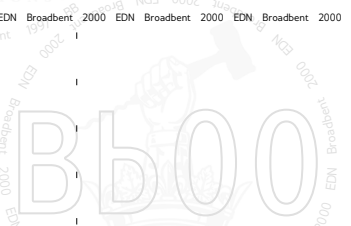

## Bb2005

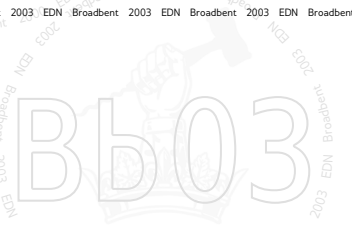

## Bb2007

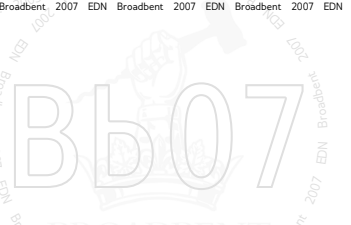

## Bb2011

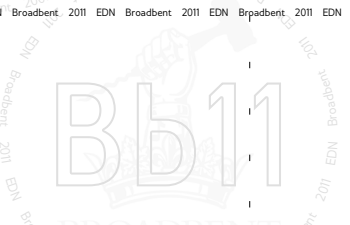



# Bb Auction Reserve



# Bb1994

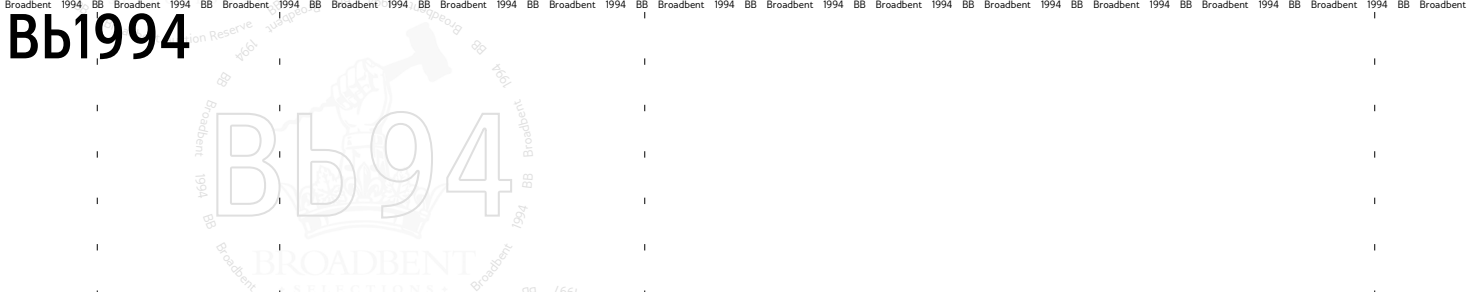

# Bb1997

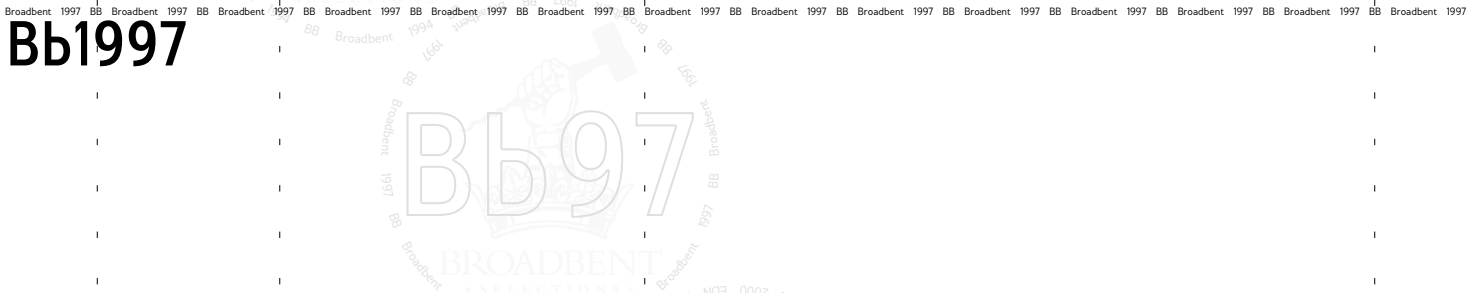

# Bb2002

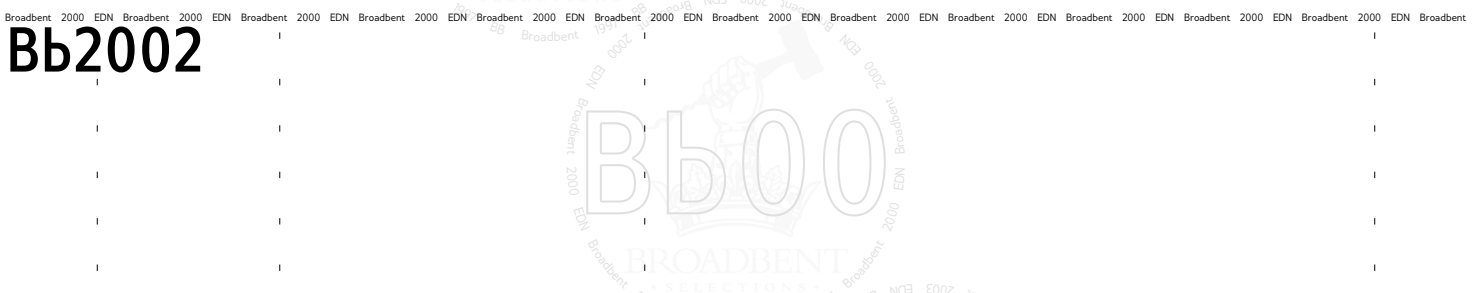

# Bb2005

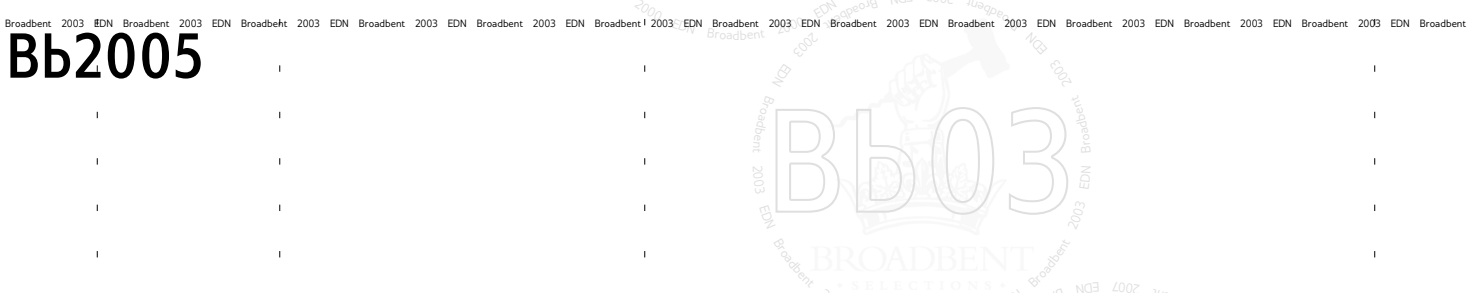

# Bb2007

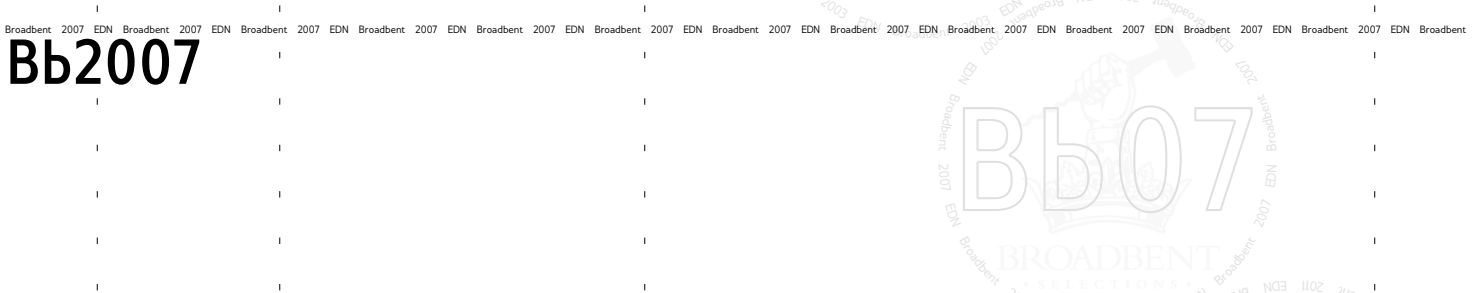

# Bb2011

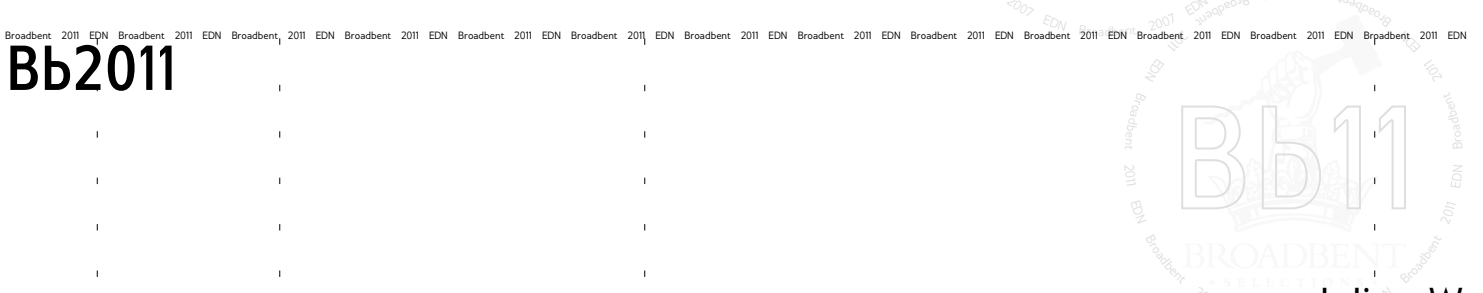

Julian W.



# Bb Auction Reserve



# Bb1994

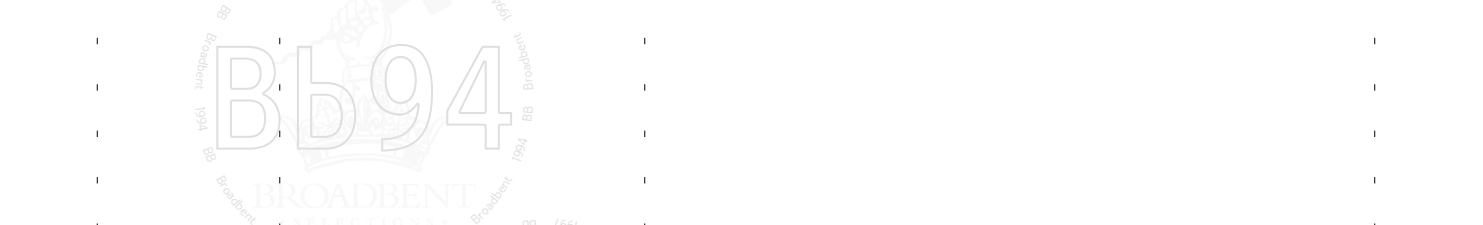

# Bb1997



# Bb2002



# Bb2005



# Bb2007



# Bb2011



Times Eye Nose Mouth Score  
Broadbent 2015 EDN Broadbent 2015 EDN Broadbent 2015 EDN Broadbent 2015 EDN Broadbent 2015 EDN Broadbent 2015 EDN Broadbent 2015 EDN Broadbent 2015 EDN Broadbent 2015 EDN Broadbent 2015 EDN Broadbent 2015 EDN Broadbent 2015 EDN

# Bb2015



Bb15

# Ni2011



Ni11

# Ps1992



Ps92

# W1991



W91

# F1985



F85

# Gc1983



GC83

# ???



???



Times Eye Nose Mouth Score

# Bb Auction Reserve

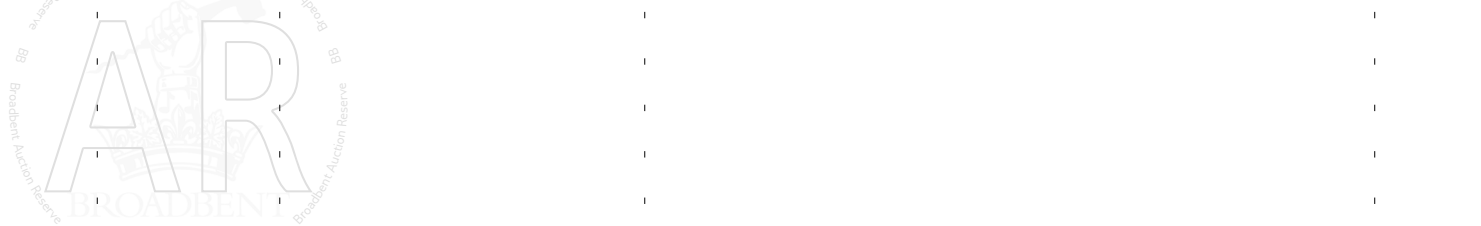

# Bb1994

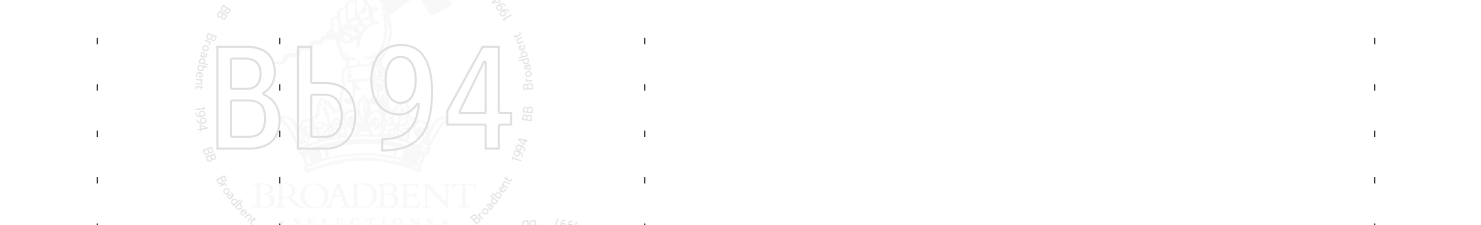

# Bb1997



# Bb2002



# Bb2005



# Bb2007

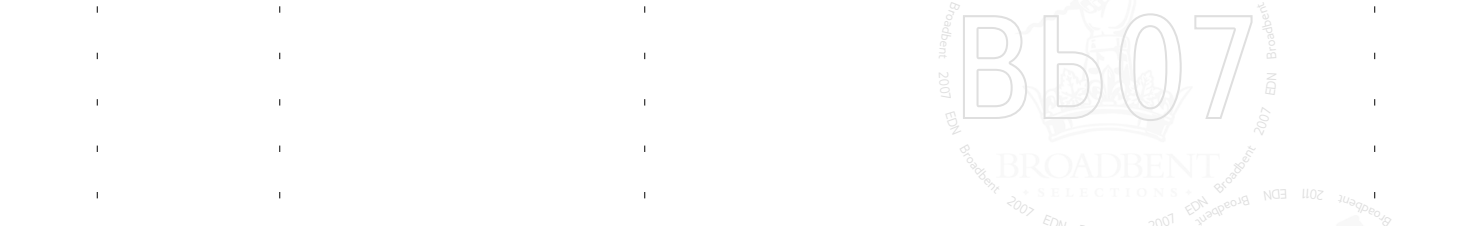

# Bb2011

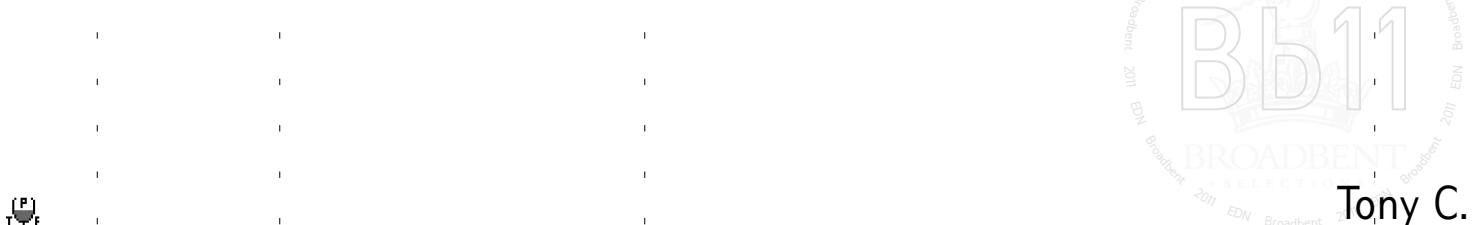



Times			Eye			Nose			Mouth			Score					
Broadbent	2015	EDN	Broadbent	2015	EDN	Broadbent	2015	EDN	Broadbent	2015	EDN	Broadbent	2015	EDN	Broadbent	2015	EDN

# Bb2015



Niepoort			JDAW			Niepoort			JDAW			Niepoort			JDAW			Niepoort			JDAW		
2011	2011	EDN	2011	2011	EDN	2011	2011	EDN	2011	2011	EDN	2011	2011	EDN	2011	2011	EDN	2011	2011	EDN	2011	2011	EDN

# Ni2011



# Ni11

Niepoort			CPR			Niepoort			CPR			Niepoort			CPR			Niepoort			CPR		
Quinta do Passadouro	1992	EDN	Quinta do Passadouro	1992	EDN	Quinta do Passadouro	1992	EDN	Quinta do Passadouro	1992	EDN	Quinta do Passadouro	1992	EDN	Quinta do Passadouro	1992	EDN	Quinta do Passadouro	1992	EDN	Quinta do Passadouro	1992	EDN

# Ps1992



# Ps92

Warre			PW			Warre			PW			Warre			PW			Warre			PW		
1991	1991	EDN	1991	1991	EDN	1991	1991	EDN	1991	1991	EDN	1991	1991	EDN	1991	1991	EDN	1991	1991	EDN	1991	1991	EDN

# W1991



# W91

Fonseca			JDAW			Fonseca			JDAW			Fonseca			JDAW			Fonseca			JDAW		
1985	1985	EDN	1985	1985	EDN	1985	1985	EDN	1985	1985	EDN	1985	1985	EDN	1985	1985	EDN	1985	1985	EDN	1985	1985	EDN

# F1985



# F85

Could Campbell			MPM			Could Campbell			MPM			Could Campbell			MPM			Could Campbell			MPM		
1983	1983	EDN	1983	1983	EDN	1983	1983	EDN	1983	1983	EDN	1983	1983	EDN	1983	1983	EDN	1983	1983	EDN	1983	1983	EDN

# Gc1983



# Gc83

Novelty			AHB			Novelty			AHB			Novelty			AHB			Novelty			AHB		
1983	1983	EDN	1983	1983	EDN	1983	1983	EDN	1983	1983	EDN	1983	1983	EDN	1983	1983	EDN	1983	1983	EDN	1983	1983	EDN

# ???



# ???



Times Eye Nose Mouth Score  
Broadbent Auction Reserve BB Broadbent Auction Reserve BB Broadbent Auction Reserve BB Broadbent Auction Reserve BB Broadbent Auction Reserve BB Broadbent Auction Reserve BB Broadbent Auction Reserve BB Broadbent Auction Reserve BB Broadbent Auction Reserve BB Broadbent Auction Reserve BB Broadbent Auction Reserve BB Broadbent Auction Reserve BB

# Bb Auction Reserve



# Bb1994



# Bb1997



# Bb2002



# Bb2005



# Bb2007

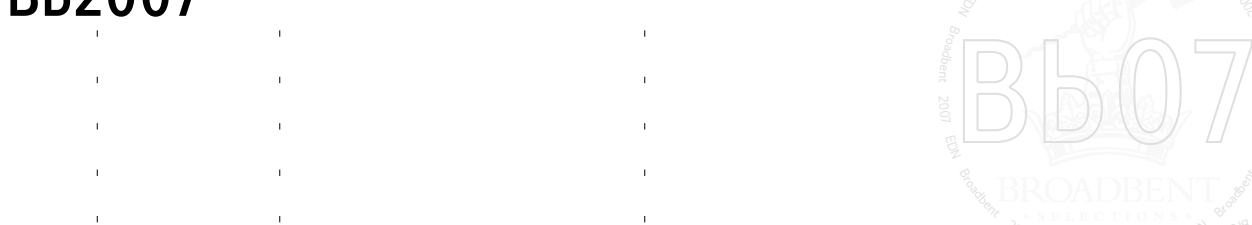

# Bb2011

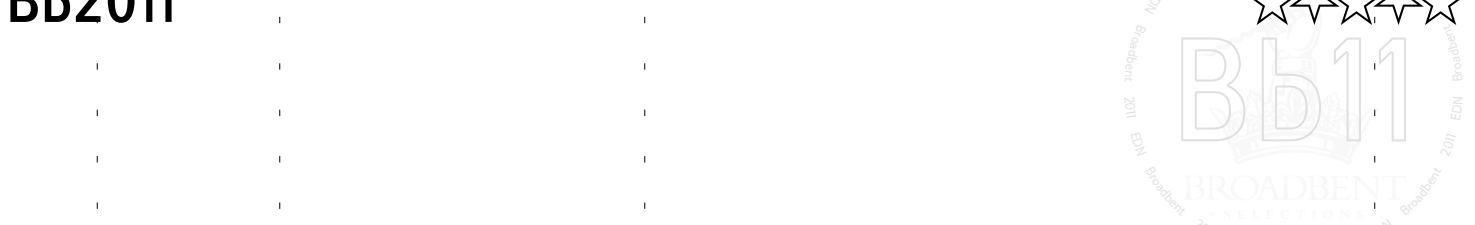

Times Eye Nose Mouth Score  
Broadbent 2015 EDN Broadbent 2015 EDN Broadbent 2015 EDN Broadbent 2015 EDN Broadbent 2015 EDN Broadbent 2015 EDN Broadbent 2015 EDN Broadbent 2015 EDN Broadbent 2015 EDN Broadbent 2015 EDN

# Bb2015



# Ni2011



# Ps1992



# W1991



# F1985



# Gc1983



# ???



# Bb Auction Reserve



# Bb1994

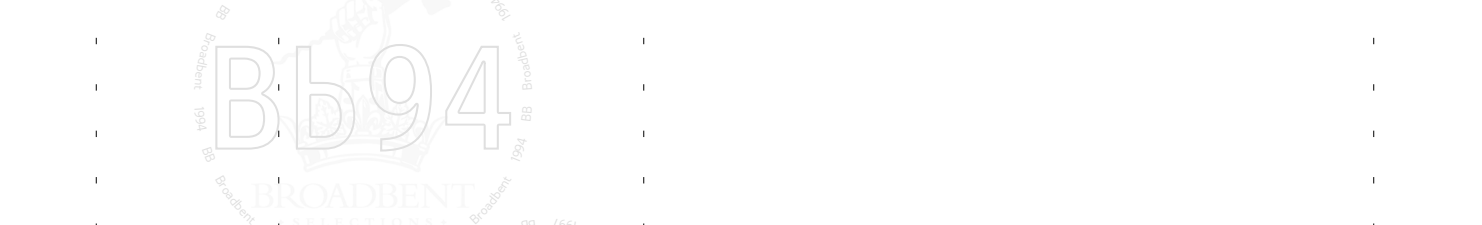

# Bb1997



# Bb2002

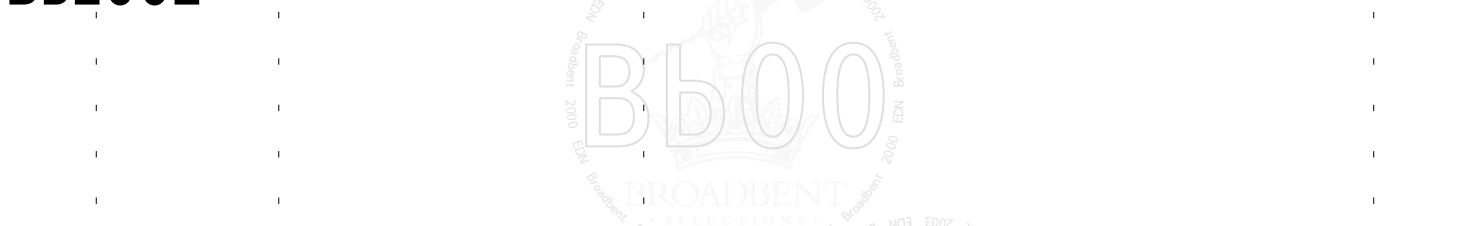

# Bb2005



# Bb2007

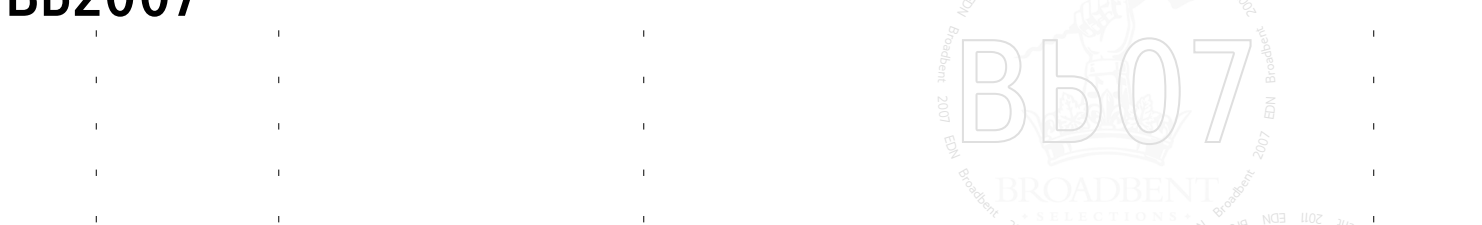

# Bb2011

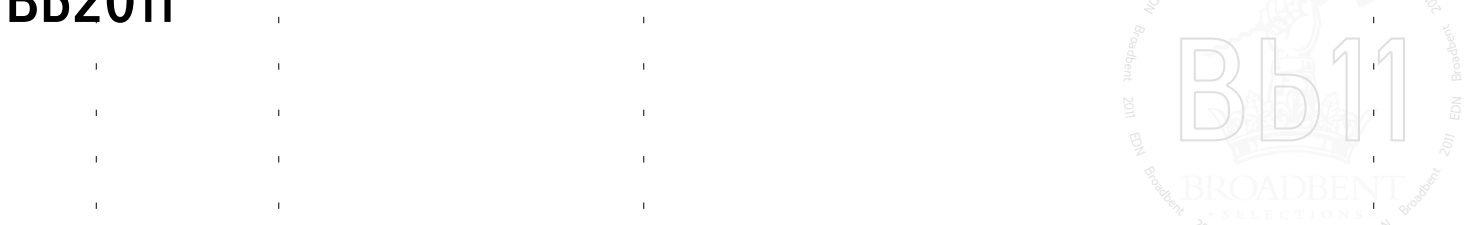

Times				Eye				Nose				Mouth				Score					
Broadbent	2015	EDN	Broadbent	2015	EDN	Broadbent	2015	EDN	Broadbent	2015	EDN	Broadbent	2015	EDN	Broadbent	2015	EDN	Broadbent	2015	EDN	Broadbent

# Bb2015

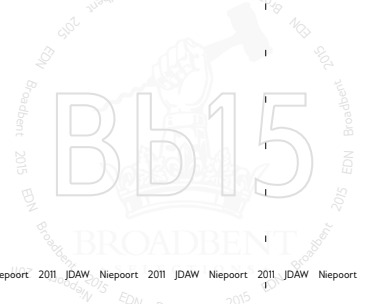

# Ni2011



# Ps1992



# W1991



# F1985



# Gc1983



# ???



Times Eye Nose Mouth Score  
Broadbent Auction Reserve BB Broadbent Auction Reserve BB Broadbent Auction Reserve BB Broadbent Auction Reserve BB Broadbent Auction Reserve BB Broadbent Auction Reserve BB Broadbent Auction Reserve BB Broadbent Auction Reserve BB Broadbent Auction Reserve BB Broadbent Auction Reserve BB

# Bb Auction Reserve



# Bb1994

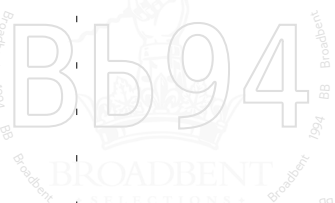

# Bb1997

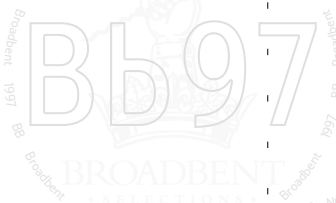

# Bb2002



# Bb2005



# Bb2007



# Bb2011



Times Eye Nose Mouth Score  
Broadbent 2015 EDN Broadbent 2015 EDN Broadbent 2015 EDN Broadbent 2015 EDN Broadbent 2015 EDN Broadbent 2015 EDN Broadbent 2015 EDN Broadbent 2015 EDN Broadbent 2015 EDN

# Bb2015

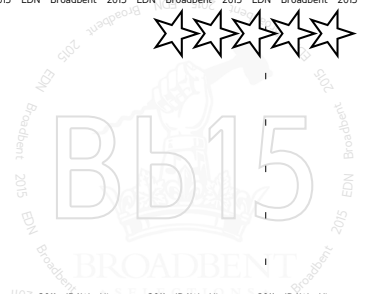

# Ni2011



# Ps1992



# W1991

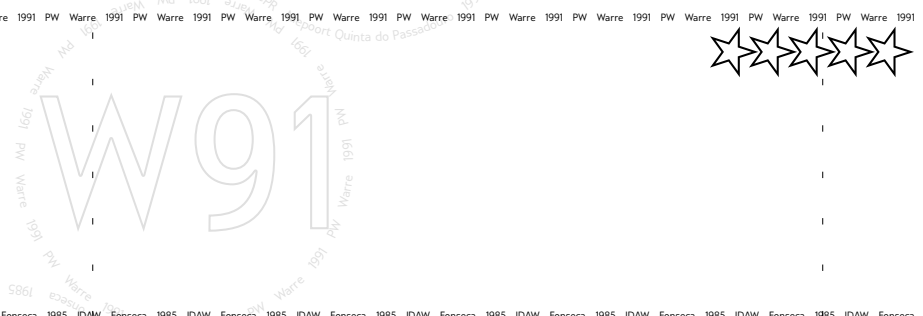

# F1985

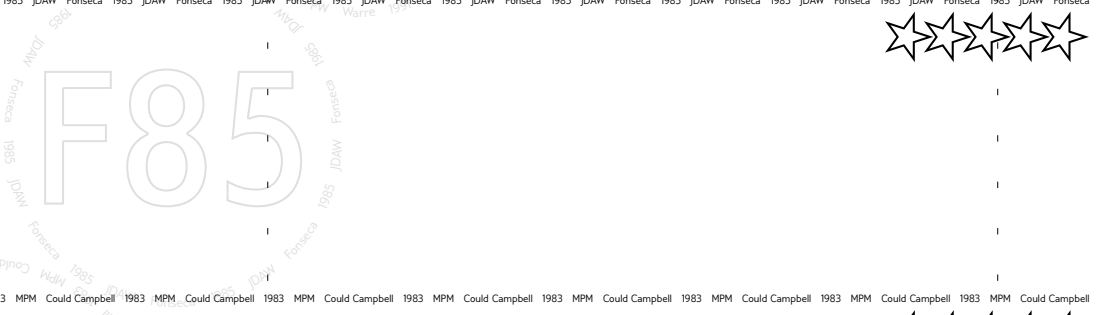

# Gc1983

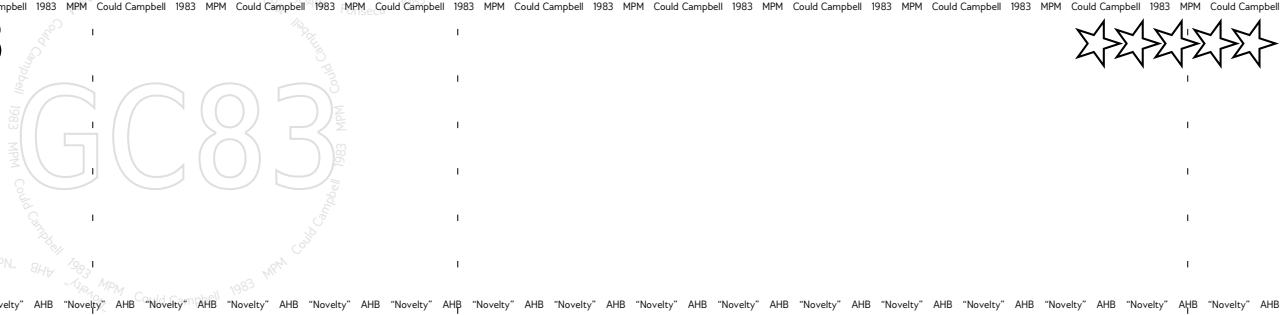

# ???

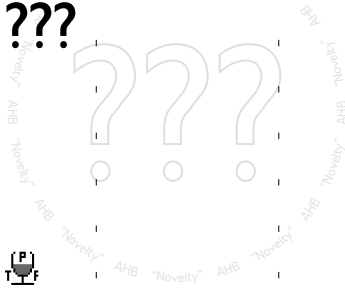

Times Eye Nose Mouth Score  
Broadbent Auction Reserve BB Broadbent Auction Reserve BB Broadbent Auction Reserve BB Broadbent Auction Reserve BB Broadbent Auction Reserve BB Broadbent Auction Reserve BB Broadbent Auction Reserve BB Broadbent Auction Reserve BB Broadbent Auction Reserve BB

# Bb Auction Reserve



# Bb1994

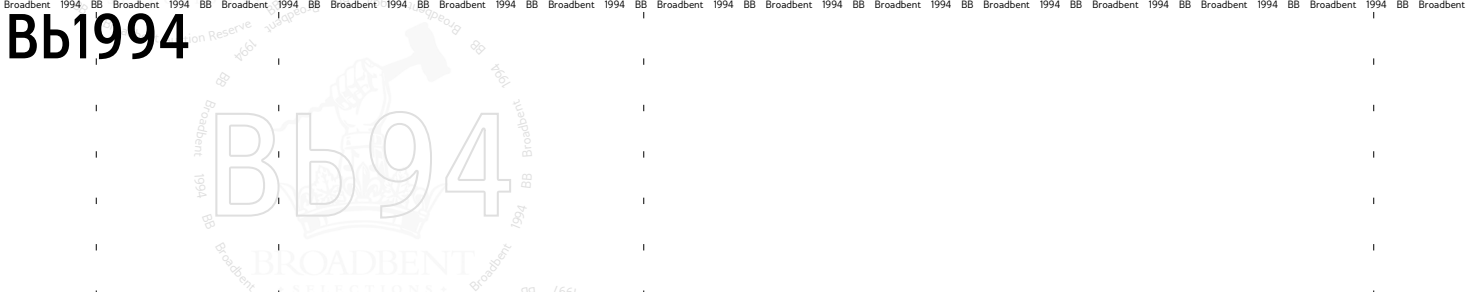

# Bb1997

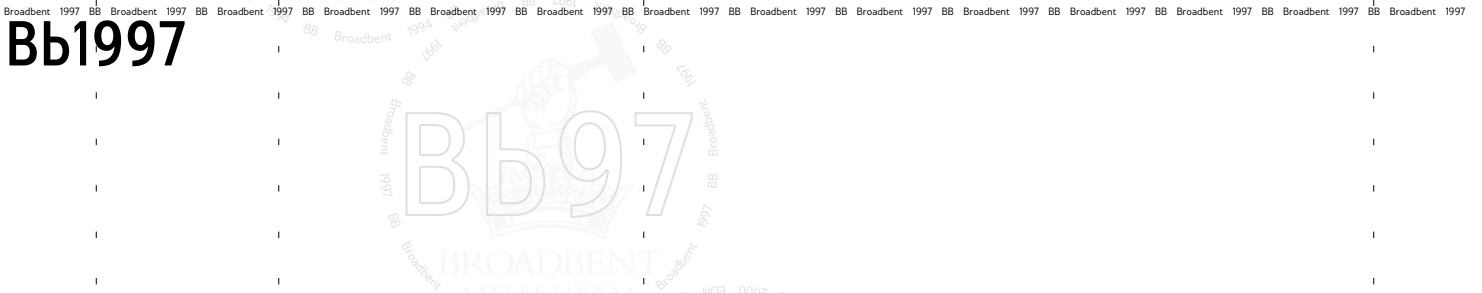

# Bb2002

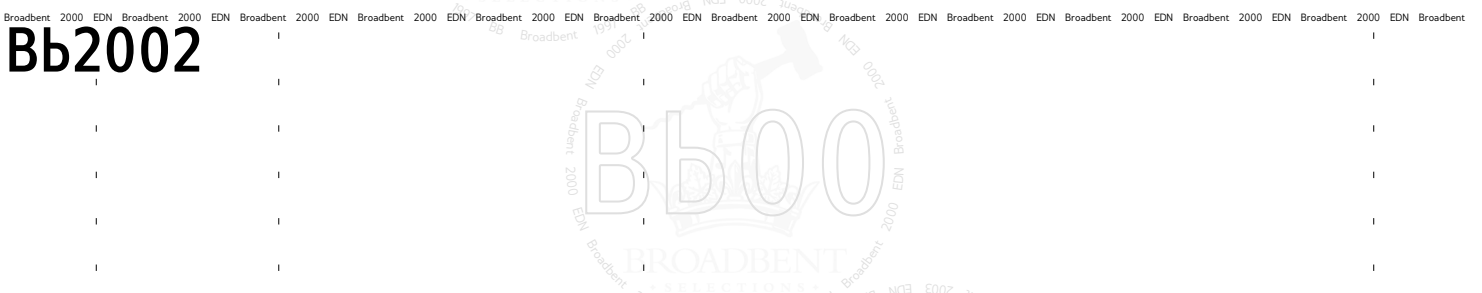

# Bb2003

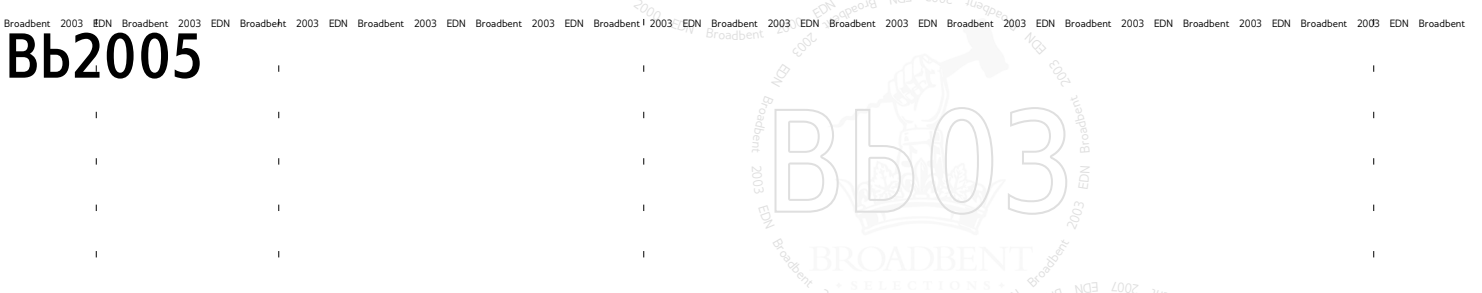

# Bb2007

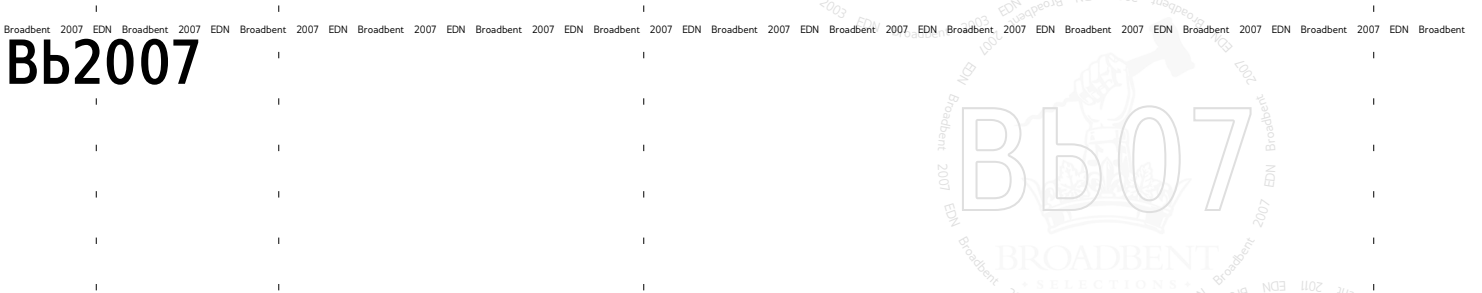

# Bb2011

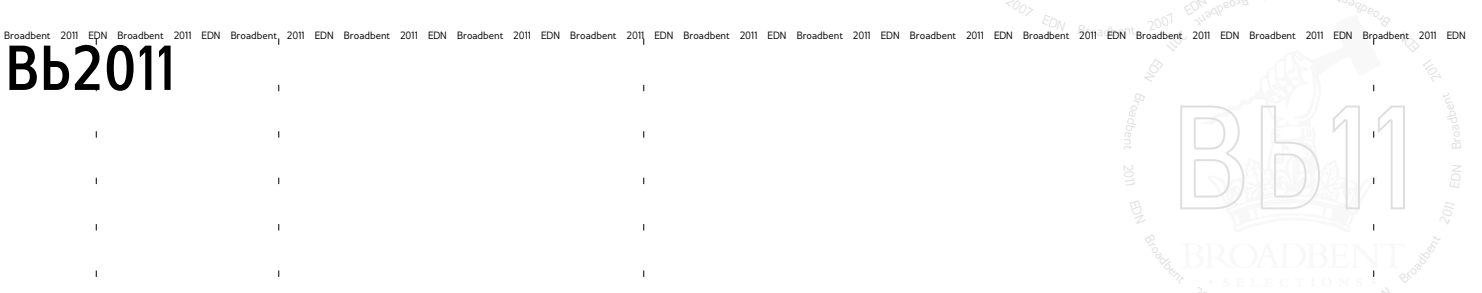





Times Eye Nose

Mouth Score

Bb Auction Reserve



Bb1994

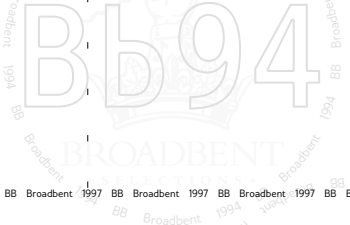

Bb1997

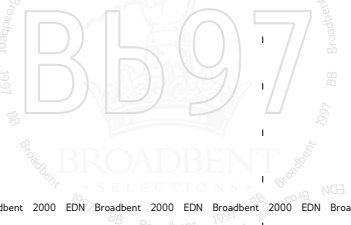

Bb2002

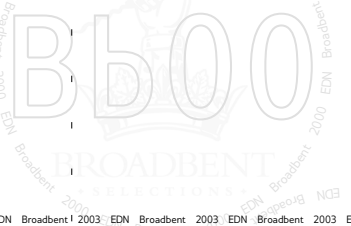

Bb2005



Bb2007



Bb2011



lan J.



# Bb Auction Reserve



# Bb1994



# Bb1997



# Bb2002



# Bb2005



# Bb2007



# Bb2011



















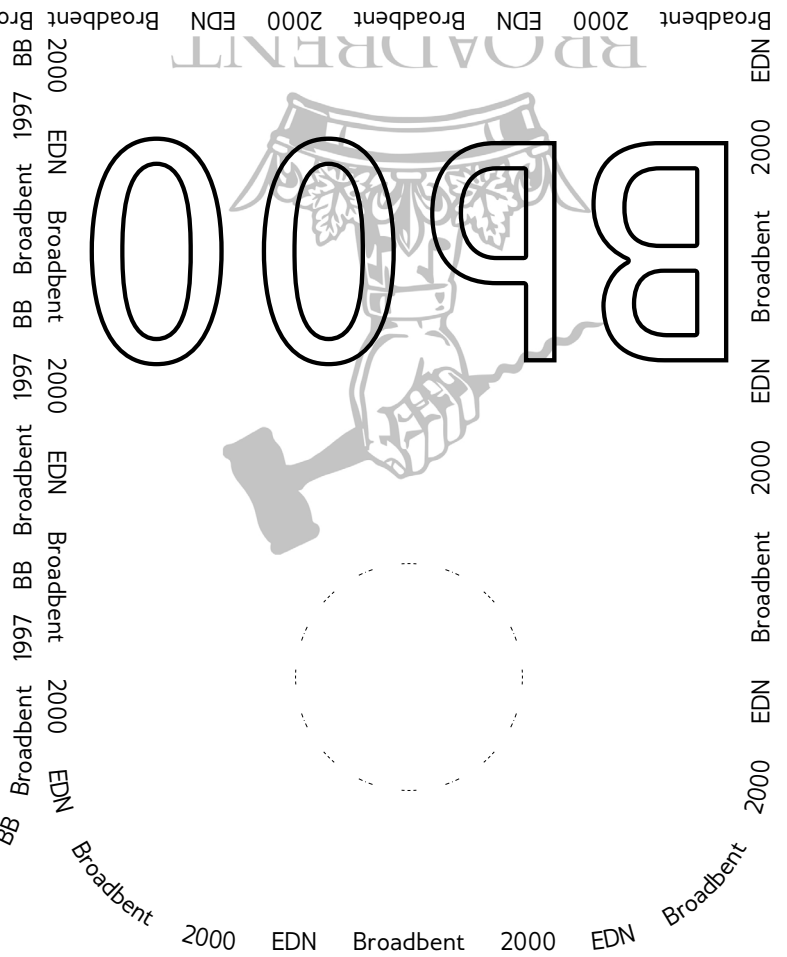
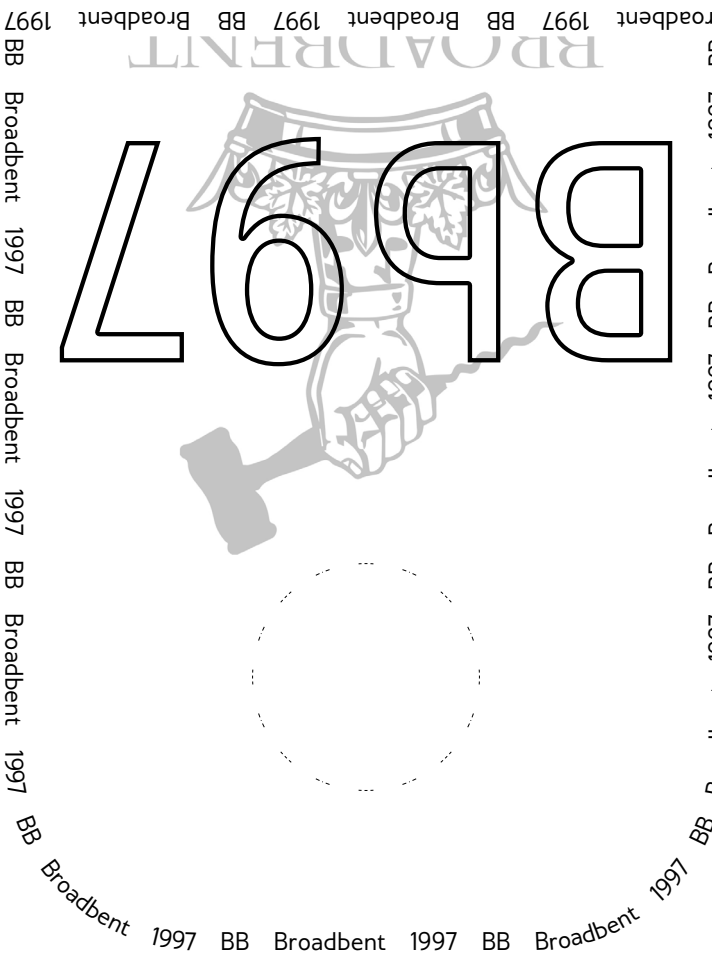
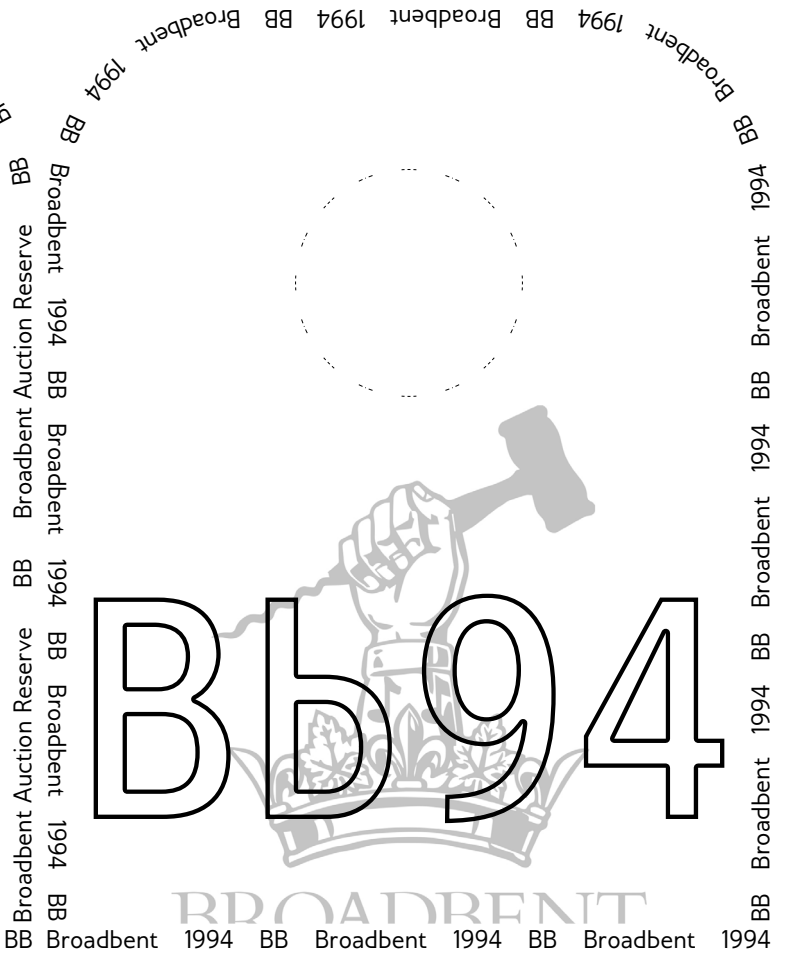
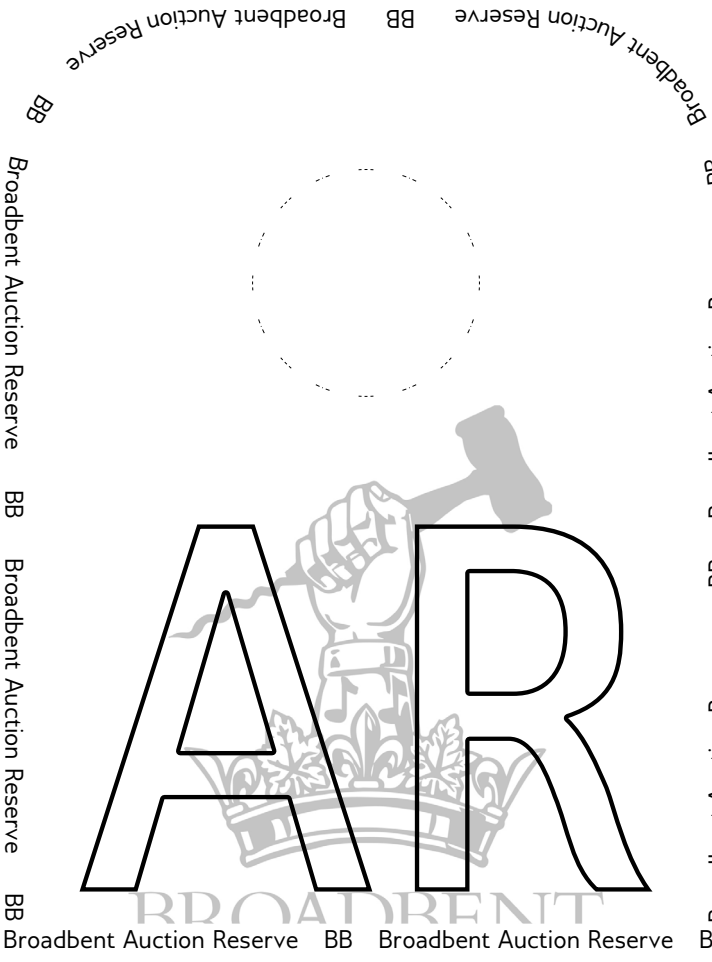

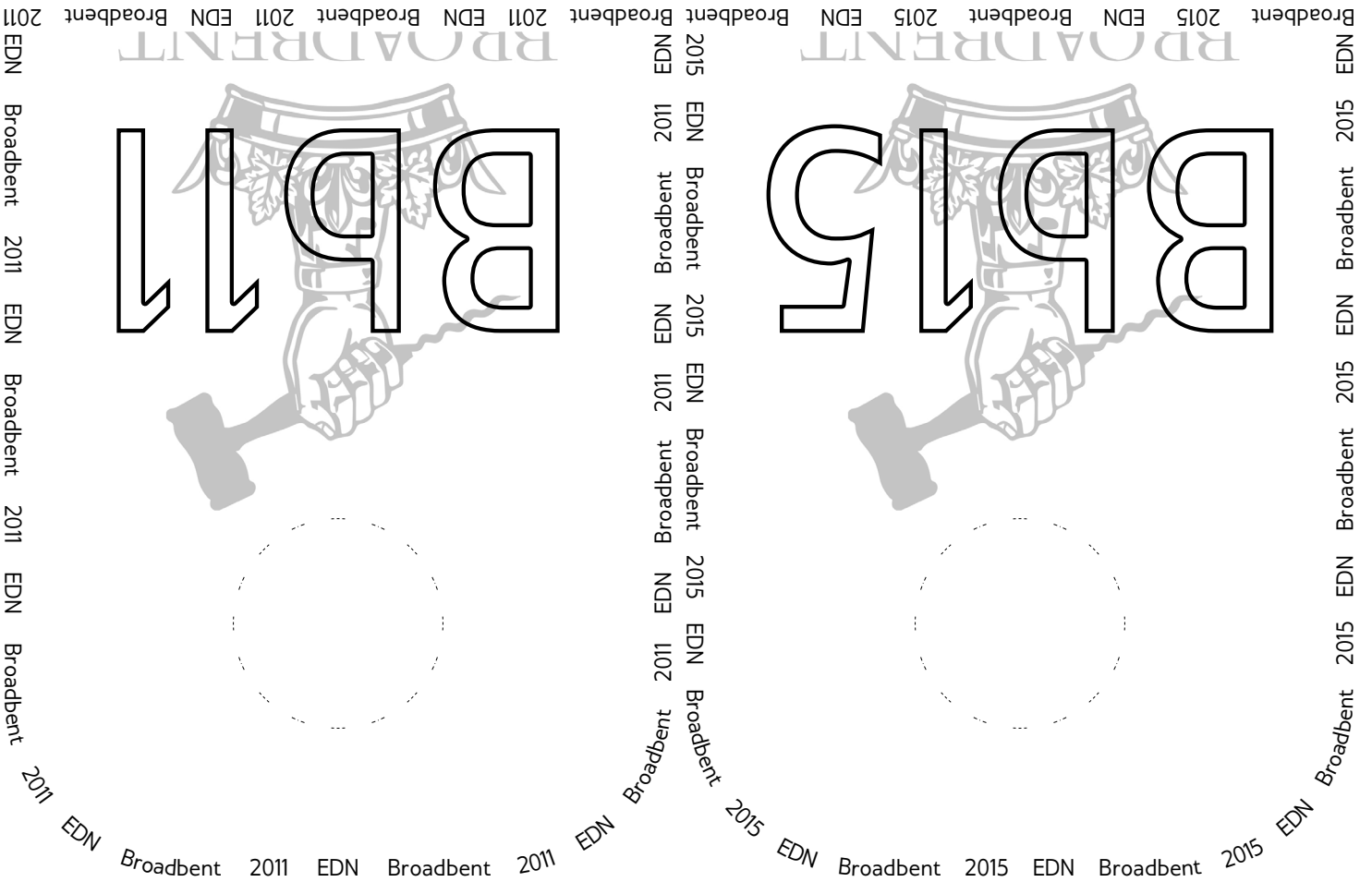
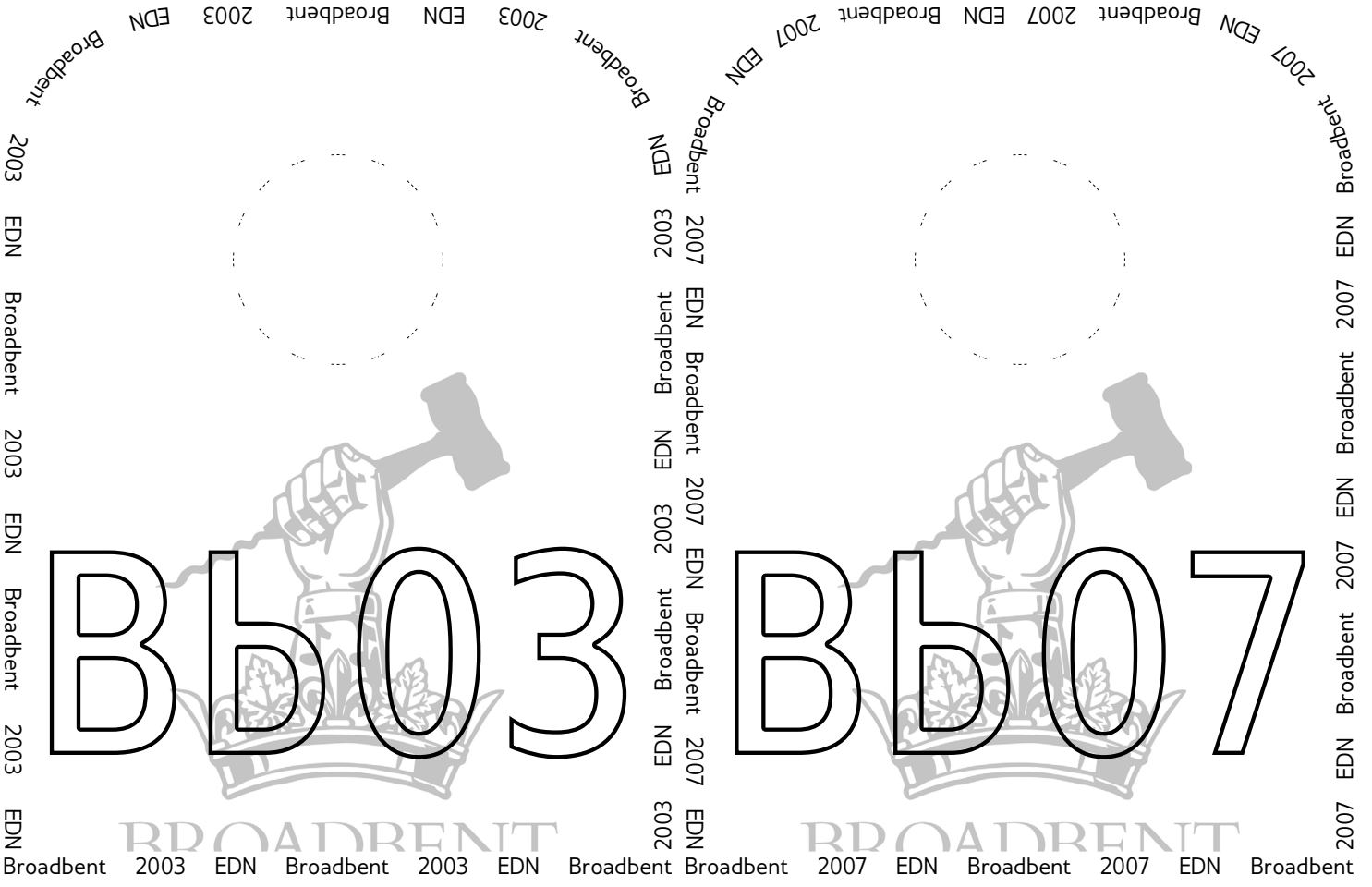

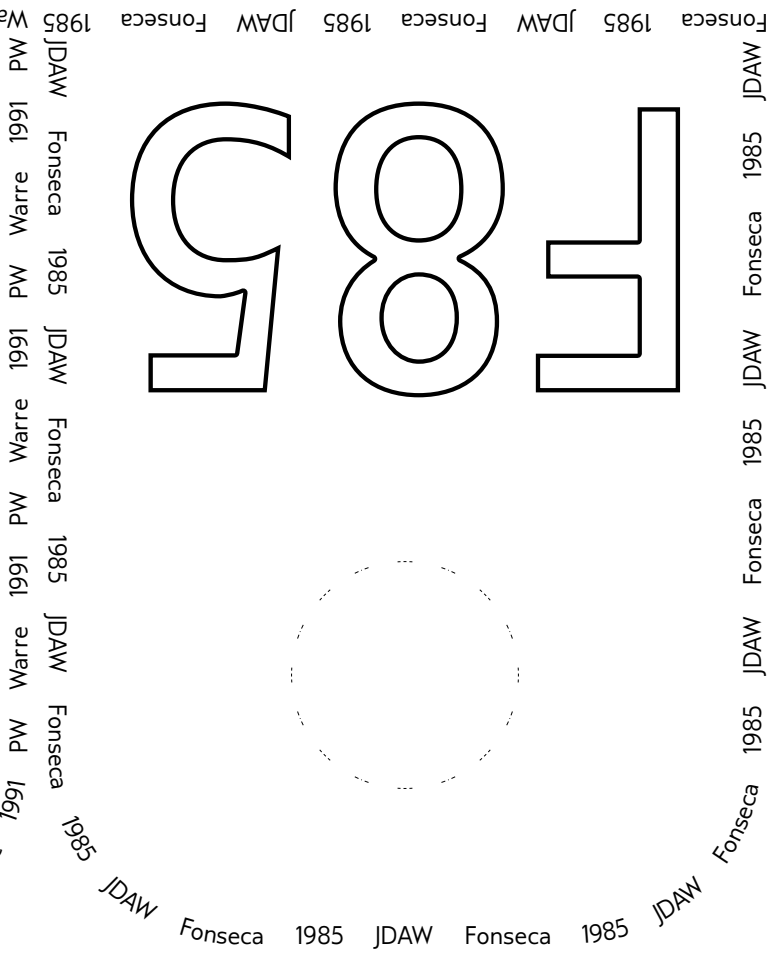
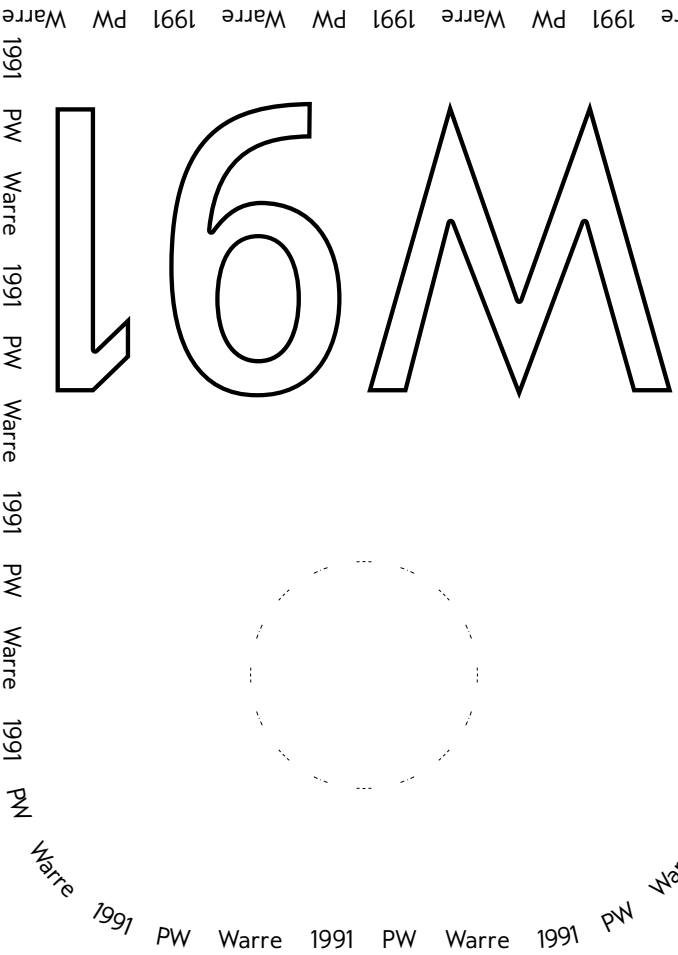
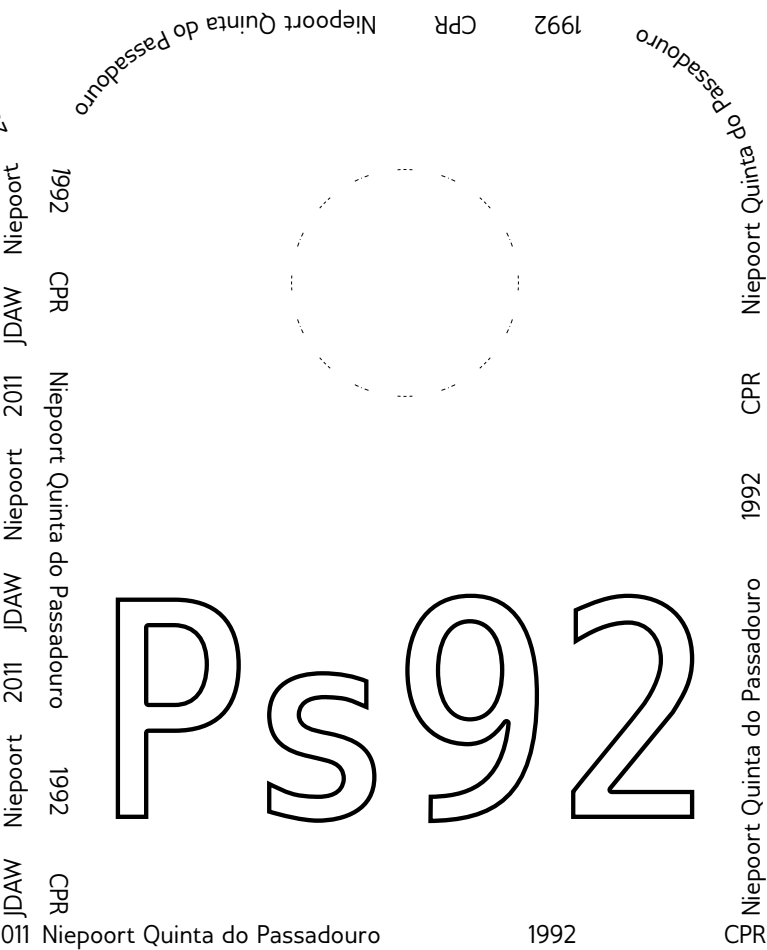
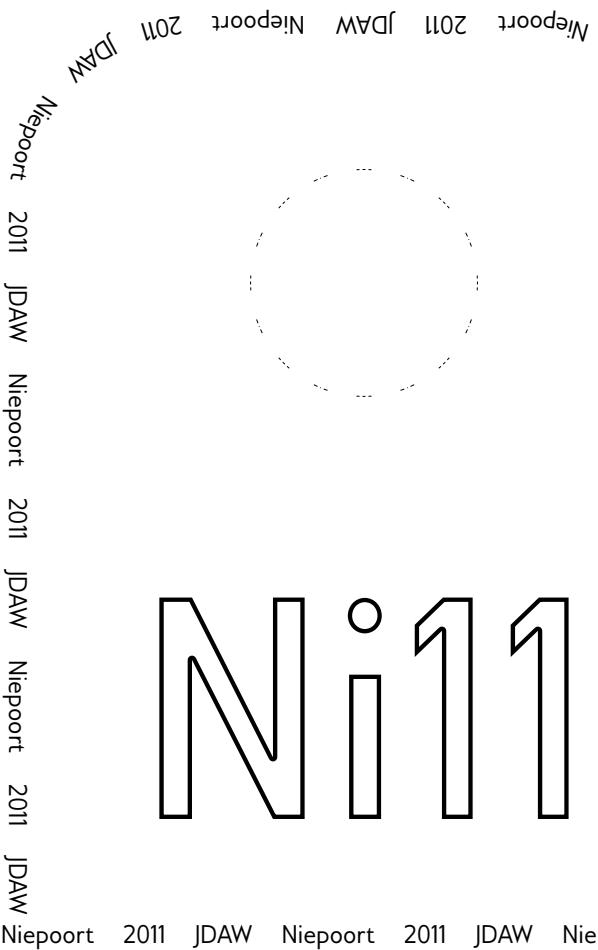



Broadbent Auction Reserve

BR  
BB

Broadbent Auction Reserve

BB

Auction Reserve

Broadbent Auction Reserve



Broadbent Auction Reserve



Broadbent Auction Reserve

BR  
BB

BB

Broadbent Auction Reserve

BB

Broadbent Auction Reserve



BROADBENT



Broadbent Auction Reserve



Broadbent 1994 BB Broadbent 1994 BB Broadbent 1994 BB Broadbent 1994 BB Broadbent 1994 BB Broadbent 1994 BB Broadbent 1994 BB Broadbent 1994 BB Broadbent 1994 BB

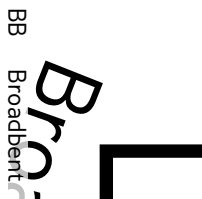
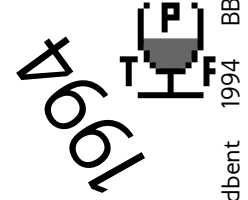
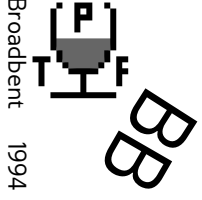

# BLO94

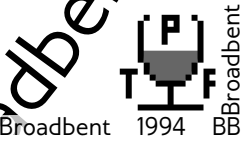
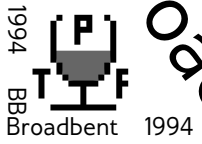
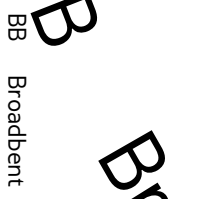
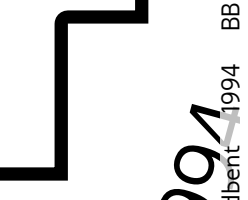
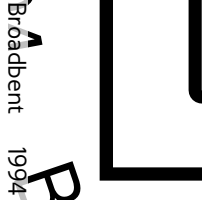
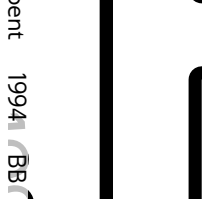
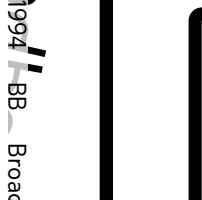

Broadbent 1994 BB Broadbent 1994 BB Broadbent 1994 BB Broadbent 1994 BB Broadbent 1994 BB Broadbent 1994 BB Broadbent 1994 BB Broadbent 1994 BB Broadbent 1994 BB

BROADBENT





Broadbent 2000 EDN Broadbent 2000 EDN Broadbent 2000 EDN Broadbent 2000 EDN Broadbent 2000 EDN Broadbent 2000 EDN Broadbent 2000 EDN Broadbent 2000 EDN Broadbent 2000 EDN

2000 EDN Broadbent 2000 EDN

2000 EDN Broadbent 2000 EDN

Broadbent 2000 EDN

Broadbent 2000 EDN

# BROADBENT

EDN Broadbent 2000 EDN

EDN Broadbent 2000 EDN

Broadbent 2000 EDN

Broadbent 2000 EDN

Broadbent 2000 EDN Broadbent 2000 EDN Broadbent 2000 EDN Broadbent 2000 EDN Broadbent 2000 EDN Broadbent 2000 EDN Broadbent 2000 EDN Broadbent 2000 EDN Broadbent 2000 EDN

BROADBENT



Broadbent 2003 EDN Broadbent 2003 EDN Broadbent 2003 EDN Broadbent 2003 EDN Broadbent 2003 EDN Broadbent 2003 EDN Broadbent 2003 EDN Broadbent 2003 EDN Broadbent 2003 EDN

2003 EDN Broadbent 2003 EDN Broadbent 2003 EDN

2003 EDN Broadbent 2003 EDN Broadbent 2003 EDN

Broadbent 2003 EDN

Broadbent 2003 EDN

# BLOB

EDN Broadbent 2003 EDN

2003 EDN Broadbent 2003 EDN

2003 EDN Broadbent 2003 EDN

Broadbent 2003 EDN

2003 EDN Broadbent 2003 EDN Broadbent 2003 EDN Broadbent 2003 EDN Broadbent 2003 EDN Broadbent 2003 EDN Broadbent 2003 EDN Broadbent 2003 EDN Broadbent 2003 EDN

# BROADBENT

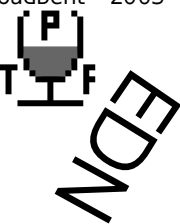

Broadbent 2007 EDN Broadbent 2007 EDN Broadbent 2007 EDN Broadbent 2007 EDN Broadbent 2007 EDN Broadbent 2007 EDN Broadbent 2007 EDN Broadbent 2007 EDN Broadbent 2007 EDN

2007 EDN Broadbent 2007 EDN

2007 EDN Broadbent 2007 EDN

Broadbent 2007 EDN

Broadbent 2007 EDN

# BLOO 7

EDN Broadbent 2007 EDN

2007 EDN Broadbent 2007 EDN

2007 EDN Broadbent 2007 EDN

Broadbent 2007 EDN

2007 EDN Broadbent 2007 EDN Broadbent 2007 EDN Broadbent 2007 EDN Broadbent 2007 EDN Broadbent 2007 EDN Broadbent 2007 EDN Broadbent 2007 EDN Broadbent 2007 EDN

# BROADBENT



Broadbent 2011 EDN Broadbent 2011 EDN Broadbent 2011 EDN Broadbent 2011 EDN Broadbent 2011 EDN Broadbent 2011 EDN Broadbent 2011 EDN Broadbent 2011 EDN Broadbent 2011 EDN

EDN  
Broadbent 2011  
EDN

Broadbent 2011  
EDN

Broadbent 2011  
EDN

EDN  
Broadbent 2011

Broadbent 2011  
EDN

2011  
Broadbent 2011  
EDN

Broadbent 2011  
EDN

Broadbent 2011  
EDN

2011  
Broadbent 2011  
EDN

Broadbent 2011  
EDN

# BFD11

# BROADBENT



EDN  
Broadbent  
2015

2015  
Broadbent  
EDN

Broadbent  
2015  
EDN

Broadbent  
2015  
EDN

# BFB15

EDN  
Broadbent  
2015

2015  
Broadbent  
EDN

Broadbent  
2015  
EDN

Broadbent  
2015  
EDN

# BROADBENT

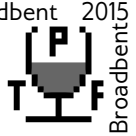
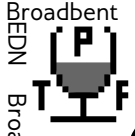





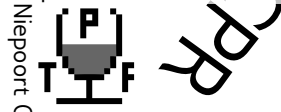

Niepoort  
1992

1992  
Niepoort

# PSQZ

CPR  
Niepoort Quinta do Passadouro

CPR  
Niepoort Quinta do Passadouro

1992  
CPR  
Niepoort Quinta do Passadouro

1992  
CPR  
Niepoort Quinta do Passadouro





JDAW  
1985

Fonseca

1985 JDAW

Fonseca

1985 JDAW

Fonseca

1985 JDAW

Fonseca

1985 JDAW

1985

1985

1985

Fonseca

1985 JDAW



1985

JDAW

Fonseca

1985 JDAW

Fonseca

1985 JDAW

Fonseca

1985 JDAW



1985

JDAW

Fonseca

1985 JDAW

Fonseca

1985 JDAW

Fonseca

1985 JDAW

Fonseca

Could Campbell 1983 MPM Could Campbell 1983 MPM Could Campbell 1983 MPM Could Campbell 1983 MPM Could Campbell 1983 MPM Could Campbell 1983 MPM

Could Campbell 1983 MPM

Could Campbell 1983 MPM

Could Campbell 1983 MPM

Could Campbell 1983 MPM

Could Campbell 1983 MPM

Could Campbell 1983 MPM

Could Campbell 1983 MPM

Could Campbell 1983 MPM

Could Campbell 1983 MPM

Could Campbell 1983 MPM Could Campbell 1983 MPM Could Campbell 1983 MPM Could Campbell 1983 MPM Could Campbell 1983 MPM Could Campbell 1983 MPM

G

C

8

3

Could Campbell 1983 MPM

Could Campbell 1983 MPM

Could Campbell 1983 MPM

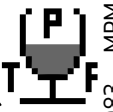



Bart B.

Boot & Flogger, Wednesday 1<sup>st</sup> May 2019

Broadbent

[www.Broadbent.com](http://www.Broadbent.com), [www.ThePortForum.com](http://www.ThePortForum.com), [www.jdawiseman.com](http://www.jdawiseman.com)

Bart B.

Fold sheet in half, then along dashed lines. Press hard on folds. Side with header to face named person; side without to face away.

W!c!y!e!c!

Boot & Flogger, Wednesday 1<sup>st</sup> May 2019

Broadbent

[www.Broadbent.com](http://www.Broadbent.com), [www.ThePortForum.com](http://www.ThePortForum.com), [www.jdawiseman.com](http://www.jdawiseman.com)

Michael C.

Fold sheet in half, then along dashed lines. Press hard on folds. Side with header to face named person; side without to face away.

Charles R.

Boot & Flogger, Wednesday 1<sup>st</sup> May 2019

Broadbent

[www.Broadbent.com](http://www.Broadbent.com), [www.ThePortForum.com](http://www.ThePortForum.com), [www.jdawiseman.com](http://www.jdawiseman.com)

Charles R.

Fold sheet in half, then along dashed lines. Press hard on folds. Side with header to face named person; side without to face away.



Jörgen B.

Boot & Flogger, Wednesday 1<sup>st</sup> May 2019

Broadbent

[www.Broadbent.com](http://www.Broadbent.com), [www.ThePortForum.com](http://www.ThePortForum.com), [www.jdawiseman.com](http://www.jdawiseman.com)

Jörgen B.

Fold sheet in half, then along dashed lines. Press hard on folds. Side with header to face named person; side without to face away.

' d u o w i s

Boot & Flogger, Wednesday 1<sup>st</sup> May 2019

Broadbent

[www.Broadbent.com](http://www.Broadbent.com), [www.ThePortForum.com](http://www.ThePortForum.com), [www.jdawiseman.com](http://www.jdawiseman.com)

Simon D.

Fold sheet in half, then along dashed lines. Press hard on folds. Side with header to face named person; side without to face away.

Stefan S.

Boot & Flogger, Wednesday 1<sup>st</sup> May 2019

Broadbent

[www.Broadbent.com](http://www.Broadbent.com), [www.ThePortForum.com](http://www.ThePortForum.com), [www.jdawiseman.com](http://www.jdawiseman.com)

Stefan S.

Fold sheet in half, then along dashed lines. Press hard on folds. Side with header to face named person; side without to face away.

W u e i n f

Boot & Flogger, Wednesday 1<sup>st</sup> May 2019

Broadbent

[www.Broadbent.com](http://www.Broadbent.com), [www.ThePortForum.com](http://www.ThePortForum.com), [www.jdawiseman.com](http://www.jdawiseman.com)

Julian W.

Fold sheet in half, then along dashed lines. Press hard on folds. Side with header to face named person; side without to face away.

M!KE M.

Boot & Flogger, Wednesday 1<sup>st</sup> May 2019

Broadbent

[www.Broadbent.com](http://www.Broadbent.com), [www.ThePortForum.com](http://www.ThePortForum.com), [www.jdawiseman.com](http://www.jdawiseman.com)

Mike M.

Fold sheet in half, then along dashed lines. Press hard on folds. Side with header to face named person; side without to face away.

· Tony C.

Boot & Flogger, Wednesday 1<sup>st</sup> May 2019

Broadbent

[www.Broadbent.com](http://www.Broadbent.com), [www.ThePortForum.com](http://www.ThePortForum.com), [www.jdawiseman.com](http://www.jdawiseman.com)

Tony C.

Fold sheet in half, then along dashed lines. Press hard on folds. Side with header to face named person; side without to face away.

Dave

Boot & Flogger, Wednesday 1<sup>st</sup> May 2019

Broadbent

[www.Broadbent.com](http://www.Broadbent.com), [www.ThePortForum.com](http://www.ThePortForum.com), [www.jdawiseman.com](http://www.jdawiseman.com)

Dave L.

Fold sheet in half, then along dashed lines. Press hard on folds. Side with header to face named person; side without to face away.

Alex B.

Boot & Flogger, Wednesday 1<sup>st</sup> May 2019

Broadbent

[www.Broadbent.com](http://www.Broadbent.com), [www.ThePortForum.com](http://www.ThePortForum.com), [www.jdawiseman.com](http://www.jdawiseman.com)

Alex B.

Fold sheet in half, then along dashed lines. Press hard on folds. Side with header to face named person; side without to face away.



W. Phil

Boot & Flogger, Wednesday 1<sup>st</sup> May 2019

Broadbent

[www.Broadbent.com](http://www.Broadbent.com), [www.ThePortForum.com](http://www.ThePortForum.com), [www.jdawiseman.com](http://www.jdawiseman.com)

Phil W.

Fold sheet in half, then along dashed lines. Press hard on folds. Side with header to face named person; side without to face away.

Sten l.

Boot & Flogger, Wednesday 1<sup>st</sup> May 2019

Broadbent

[www.Broadbent.com](http://www.Broadbent.com), [www.ThePortForum.com](http://www.ThePortForum.com), [www.jdawiseman.com](http://www.jdawiseman.com)

Sten l.

Fold sheet in half, then along dashed lines. Press hard on folds. Side with header to face named person; side without to face away.

· f u e l

Boot & Flogger, Wednesday 1<sup>st</sup> May 2019

Broadbent

[www.Broadbent.com](http://www.Broadbent.com), [www.ThePortForum.com](http://www.ThePortForum.com), [www.jdawiseman.com](http://www.jdawiseman.com)

l a n J .

Fold sheet in half, then along dashed lines. Press hard on folds. Side with header to face named person; side without to face away.

- - - - -  
Boot & Flogger, Wednesday 1<sup>st</sup> May 2019

Broadbent

[www.Broadbent.com](http://www.Broadbent.com), [www.ThePortForum.com](http://www.ThePortForum.com), [www.jdawiseman.com](http://www.jdawiseman.com)

- - - - -  
Fold sheet in half, then along dashed lines. Press hard on folds. Side with header to face named person; side without to face away.

© Copyright 2019 Julian D. A. Wiseman of www.jdawiseman.com
This work is licensed under a Creative Commons Attribution-ShareAlike 4.0 International Licence.
http://creativecommons.org/licenses/by-sa/4.0/deed.en

product = Acrobat Distiller 11.0; languagelevel = 3; version = 3018.101; revision = 0; usertime = 88140117
Software version = SoftwareVersionDateAdobeFormat = D:201904042215 = 22:15 Thu 04 April 2019
These placemats ~ ParametersVersionDateAdobeFormat = D:201904191330 = 13:30 Fri 19 April 2019
Used paper types: A3 = 297mm\*420mm; A4 = 210mm\*297mm.

External links for document outline:

Broadbent.com = http://www.broadbent.com/
Thread on ThePortForum.com = http://www.theportforum.com/viewtopic.php?t=12597&view=unread#unread
Latest version this placemat = http://www.jdawiseman.com/2019/20190501\_Broadbent.pdf
in list of placemats = http://www.jdawiseman.com/papers/placemat/placemats\_list.html#a20190501
Boot & Flogger = http://www.davy.co.uk/wine-bar/boot-and-flogger/
SE1 1TA, streetmap.co.uk = http://www.streetmap.co.uk/map.srf?x=532409&y=180083&z=106&pc=SE1+1TA
SE1 1TA, google.co.uk = https://goo.gl/maps/7NEiwAMEZpG2
SE1 1TA, bing.com = http://www.bing.com/maps/default.aspx?where1=SE1+1TA&cp=51.50428~-0.0935
What3Words: cafe.humid.palace = http://map.what3words.com/cafe.humid.palace
Help from comp.lang.postscript = https://groups.google.com/forum/#!topic/comp.lang.postscript/MNK3cqBa2fQ
Manual of placemat software = http://www.jdawiseman.com/papers/placemat/placemat.html
Software discussion = http://www.theportforum.com/viewtopic.php?t=175&start=9999#bottom
Parameters, examples = http://www.theportforum.com/viewtopic.php?t=5837&start=9999#bottom
Placemats, list = http://www.jdawiseman.com/papers/placemat/placemats\_list.html

Fonts: /GilliusADF-BoldCond (TitlesFont); /GilliusADF-Regular (CircletextFont, HeaderFont); /GilliusADF-Cond (NamesFont, PlaceNamesFont);
and perhaps others.

Array equalities: {Circlearrays = CirclearraysTastingNotes = CirclearraysVoteRecorder = CirclearraysCorkDisplay = CirclearraysNeckTags =
CirclearraysPrePour}; {Titles}; {TitlesTastingNotes = TitlesCorkDisplay}; {TitlesVoteRecorder}; {Names = NamesTastingNotes =
NamesVoteRecorder = NamesAccounts}; {{ NamesPlaceNames 0 get }}.

InlineTitles = true; InlineAboveTitles = true; InlineBelowTitles = true; InlineOverTitles = false; InlineTitlesMaxNumberContours = 1;
InlineTitlesBlackWidth = 1.44; InlineTitlesWhiteWidth = 2.88; InlineAboveTitlesMaxNumberContours = 1; InlineBelowTitlesMaxNumberContours =
1; InlineAboveTitlesBlackWidth = 0.72; InlineAboveTitlesWhiteWidth = 1.44; InlineBelowTitlesBlackWidth = 0.72; InlineBelowTitlesWhiteWidth =
1.44

TastingNotesCirclesBehind = true; TastingNotesCirclesBehindFadingFactorIfAllBlack = 0.125; TastingNotesCirclesBehindFadingFactorIfAnyGrey =
0.2; TastingNotesCirclesBehindTopX = { [ 0 1 0 0.5 1 1 0.5 0.5 0 ] TastingSheetNum 9 mod get }; TastingNotesCirclesBehindBottomX = { [ 0
1 0 0.5 1 1 0.5 0.5 0 ] TastingSheetNum 1 add 9 mod get }

SheetNum=0, with 14 glasses: best BaseStyle, with radius 122.466, is /DiamondsAndRectangular with 5 rows, 4 columns of 3 glasses, and 1
column with one fewer glass. Of non-margin area 73.2768% within circles = 80.7992% of infinite-plane exact-hexagonal maximum.

Radii = [ 122.466 ] => diameters ~ 86.4mm ~ 3.40", all of them.

GlassesOnSheets = [ [ 0 1 2 3 4 5 6 7 8 9 10 11 12 13 ] ]

GlassesOnTastingNotePages = [ [ 0 1 2 3 4 5 6 ] [ 7 8 9 10 11 12 13 ] ]

Titles, ASCIIified and re-arranged by GlassesOnSheets = [ [ (AR) (Bb94) (Bb00) (Bb03) (Bb07) (Bb11) (Bb15) (Ni11) (Ps92) (W91)
(F85) (GC83) (???) ] ]

TitlesOnTastingNotes, ASCIIified and re-arranged by GlassesOnTastingNotePages =

[ [ (Bb Auction Reserve) (Bb1994) (Bb1997) (Bb2002) (Bb2005) (Bb2007) (Bb2011) ]
[ (Bb2015) (Ni2011) (Ps1992) (W1991) (F1985) (Gc1983) (???) ] ]

CircletextMaxFontSizeAbsolute = 9.5; CircletextMaxFontSizeProportionRadius = 0.1; CircletextMaxFontSizeMayBeSlightlyExceeded = true.

CircletextsTweakSizeScores: Score=6.84354 and FontSizes=9.67939, all of them

CirclearraysFontSizes = 9.67939, all of them. CirclearraysFontSizes/Radii = 0.0790375, all of them.

CirclearraysUnroundedN = [ [ 5.43057 7.76105 7.80924 7.10681 7.14261 7.17679 7.46749 7.32717 7.66493 4.03952 9.49738 7.67549 6.00008
10.4116 ] ].

CirclearraysN = [ [ 5 7 7 7 7 7 7 7 4 9 7 6 10 ] ].

RadiiCirclearrayBaseline = [ 120.133 ]. RadiiCirclearrayInside = [ 113.28 ].

Binding constraints on TitleFontSizes as SheetNum, WithinPage, WithinTitles, Title: 0,0,0,AR; 0,10,10,W91; 0,12,12,GC83.

TitleFontSizes = [ [ 176.779 106.623 106.623 106.623 106.623 106.623 106.623 106.623 106.623 106.623 137.307 137.307 106.623 137.307 ] ].

Title heights / RadiiCirclearrayInsideUsableTAB = [ [ 1.0799 0.674865 0.674865 0.675806 0.675806 0.675806 0.675806 0.651334 0.664511 0.651334
0.674865 0.875136 0.870288 0.675806 0.870288 ] ].

WaterBoxes on SheetNum 0 with radius 122.466: WaterBoxesSize = 9.75567; WaterBoxesGap = 2.43892; WaterBoxesNum = 15

Neck tags: scaling factors = [ 1.12505 ] (with ThisPageOrdering = 1), and scaled TitleFontSizes = [ [ 198.886 119.956 119.956 119.956
119.956 119.956 119.956 119.956 119.956 154.477 154.477 119.956 154.477 ] ].

Foldable paper should be used for PlaceNames, as PlaceNamesFirstAndThirdFoldsFromEdge = 36.

PlaceNamesFontSizes = 214.077, all of them

Minimum of PlaceNamesFontSizes = 214.077

URL # tags: Glasses\_0 ... Glasses\_14; TastingNotes\_0 ... TastingNotes\_29; VoteRecorder\_0, VoteRecorder\_1; Accounts\_0; CorkDisplay\_0 ...
CorkDisplay\_2; NeckTags\_0 ... NeckTags\_3; PrePour\_0 ... PrePour\_13; PlaceName\_0 ... PlaceName\_14; DistillationLog; and also 14
glass-circle zooms of the form Circle\_#NameNum\_#SheetNum\_#WithinPage, the firSt being Circle\_00\_00\_00 and the last being Circle\_00\_00\_13.

Only log output remaining:

usertime = 88174900, so about 34.8 seconds to execute code, excluding parameter assignments and log page(s).

2 = vmstatus pop pop: should = 1|2 and does :-)
0 = CountClipStack: should = 0 and is :-)
0 = CountGraphicsStack: should = 0 and is :-)
3 = countdictstack: should = 3 and is :-)
0 = count: should = 0 and is :-)